

---

User's  
Manual

**ISC40□J Inductive Conductivity Sensors**  
**ISC40F□J Holders, Adapter**  
**BA20 Terminal Box**  
**WF10J Extension Cable**

IM 12D06B02-01E

---

**vigilantplant®**

# ◆ PREFACE

Thank you for purchasing our inductive conductivity measurement system.

Contents of This Manual

This manual describes the method of installing, setting the operation conditions.

ISC40□J inductive conductivity detector

ISC40F□J Holders, Adapter

BA20 junction terminal box, WF10J extension cable

To ensure that this measurement system can be operated safely and also exhibit its full performance, be sure to read this manual before use.

This manual does not describe the units in Table shown below which are the component units of the inductive conductivity transmitter system. Each of these units comes with an instruction manual, so read the applicable manuals for details of the units concerned.

Manual Name	IM No.
ISC202 2-wire Inductive Conductivity Transmitter	IM 12D06A03-01E
ISC200S Intrinsic-safe 2-wire Inductive Conductivity Transmitter	IM 12D6A2-01E
ISC402G 4-wire Inductive Conductivity Converter	IM 12D6D1-E
ISC450G 4-wire Inductive Conductivity Converter	IM 12D06D05-01E

T01E.EPS

Caution for the ISC40SJ-TT explosionproof type sensor shown as below.

The temperature of the sample solution in contact with ISC40SJ-TT sensor should be the range of -10 to +105°C.

	<b>WARNING AVERTISSEMENT 静電気注意</b> 爆発のおそれがあるので、乾布による摩擦等、 静電気が発生する操作を行わないでください。 POTENTIAL ELECTROSTATIC CHARGING HAZARD - SEE INSTRUCTIONS DANGER POTENTIEL DE CHARGES ÉLECTROSTATIQUES - VOIR INSTRUCTIONS
---	--

Ui	Ii	Pi	Li	Ci	
14.4V	20mA	190mW	28.6mH	0.2μF	
注 取扱説明書(IM 12D06)参照					
EXPLOSION PROOF			EX ia IIC T4		
AMB.TEMP. -10 ~ 60°C			PROCESS TEMPERATURE 105°C		

## ◆ For the safe use of this equipment

### (1) About This Manual

- This manual should be passed on to the end user.
- The contents of this manual are subject to change without prior notice.
- The contents of this manual shall not be reproduced or copied, in part or in whole, without permission.
- This manual explains the functions contained in this product, but does not warrant that they will suit the particular purpose of the user.
- Every effort has been made to ensure accuracy in the preparation of this manual. However, should any errors or omissions come to the attention of the user, please contact the nearest Yokogawa Electric representative or sales office.
- This manual does not cover the special specifications. This manual may be left unchanged on any change of specification, construction or parts when the change does not affect the functions or performance of the product.
- If the product is used in a manner not specified in this manual, the safety of this product may be impaired.

### (2) Safety and Modification Precautions

- Follow the safety precautions in this manual when using the product to ensure protection and safety of personnel, product and system containing the product.

### (3) The following safety symbols are used on the product as well as in this manual.



This symbol indicates that the operator must follow the instructions laid out in this manual in order to avoid the risk of personnel injury, electric shock, or fatalities. The manual describes what special care the operator must exercise to avoid such risk.



This symbol indicates that the operator must refer to the instructions in this manual in order to prevent the instrument (hardware) or software from being damaged, or a system failure from occurring.



This symbol draws attention to information essential for understanding the operation and functions.



This symbol gives information that complements the current topic.



This symbol identifies a source to which to refer.

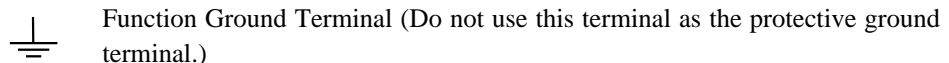

## ◆ After-sales Warranty

- Do not modify the product.
- During the warranty period, for repair under warranty carry or send the product to the local sales representative or service office. Yokogawa will replace or repair any damaged parts and return the product to you.
- Before returning a product for repair under warranty, provide us with the model name and serial number and a description of the problem. Any diagrams or data explaining the problem would also be appreciated.
- If we replace the product with a new one, we won't provide you with a repair report.
- Yokogawa warrants the product for the period stated in the pre-purchase quotation. Yokogawa shall conduct defined warranty service based on its standard. When the customer site is located outside of the service area, a fee for dispatching the maintenance engineer will be charged to the customer.
- In the following cases, customer will be charged repair fee regardless of warranty period.
  - Failure of components which are out of scope of warranty stated in instruction manual.
  - Failure caused by usage of software, hardware or auxiliary equipment, which Yokogawa Electric did not supply.
  - Failure due to improper or insufficient maintenance by user.
  - Failure due to modification, misuse or outside-of-specifications operation which Yokogawa does not authorize.
  - Failure due to power supply (voltage, frequency) being outside specifications or abnormal.
  - Failure caused by any usage out of scope of recommended usage.
  - Any damage from fire, earthquake, storms and floods, lightning, disturbances, riots, warfare, radiation and other natural changes.
- Yokogawa does not warrant conformance with the specific application at the user site. Yokogawa will not bear direct/indirect responsibility for damage due to a specific application.
- Yokogawa Electric will not bear responsibility when the user configures the product into systems or resells the product.
- Maintenance service and supplying repair parts will be covered for five years after the production ends. For repair for this product, please contact the nearest sales office described in this instruction manual.



# Contents

---

◆ PREFACE .....	i
◆ For the safe use of this equipment .....	ii
◆ After-sales Warranty .....	iii
<b>1. Introduction .....</b>	<b>1-1</b>
1.1 Features .....	1-1
1.2 Measurement principle .....	1-2
<b>2. Specifications .....</b>	<b>2-1</b>
2.1 General Specifications .....	2-1
2.1.1 ISC40□J Inductive Conductivity Sensor .....	2-1
2.1.2 ISC40FDJ Immersion Holder .....	2-2
2.1.3 ISC40FFJ Flow-through Holder .....	2-2
2.1.4 ISC40FSJ Direct Insertion Adapters .....	2-3
2.1.5 BA20 Junction Terminal Box .....	2-3
2.1.6 WF10J Extension Cable .....	2-3
2.2 Model and suffix codes .....	2-4
2.2.1 Inductive Conductivity Sensor .....	2-4
2.2.2 Immersion Holder .....	2-5
2.2.3 Flow-through Holder .....	2-5
2.2.4 Direct Insertion Adapter .....	2-6
2.2.5 Terminal Box .....	2-6
2.2.6 Extension Cable .....	2-6
2.3 External Dimensions .....	2-7
2.3.1 ISC40□J Inductive Conductivity Sensor .....	2-7
2.3.2 ISC40FDJ Immersion Holder .....	2-9
2.3.3 ISC40FFJ Flow-through Holder .....	2-11
2.3.4 ISC40FSJ Direct Insertion Adapters .....	2-15
2.3.5 BA20 Junction Terminal Box .....	2-16
2.3.6 WF10J Extension Cable .....	2-16
<b>3. Installation and Wiring .....</b>	<b>3-1</b>
3.1 Installation .....	3-1
3.1.1 Sensor Mounting .....	3-1
3.2 Caution when install the sensor .....	3-8
3.2.1 Instructions for the mounting of the ISC40□J Inductive Conductivity Sensor in a fitting —Different mounting procedures depending on sealing method .....	3-8
3.2.2 How to mount the sensor using an O-ring— When an O-ring is installed in a fitting — .....	3-9
3.2.3 How to mount the sensor using a gasket .....	3-14
— When an O-ring is not installed in a fitting — .....	3-14
3.3 Wiring .....	3-15
3.3.1 General Cautions .....	3-15
3.3.2 Connecting Sensor via Terminal Box (BA20) and Extension cable (WF10J) .....	3-16

**Appendix 1 Caution when install the detector in the ISC40F□ fittings ..... A1-1**

- A1.1 Instructions for the mounting of the ISC40□ Inductive Conductivity Detector in a fitting —Different mounting procedures depending on sealing method ..... A1-1
- A1.2 How to mount the sensor using an O-ring— When an O-ring is installed in a fitting — ..... A1-3
- A1.3 How to mount the sensor using a gasket .....  
— When an O-ring is not installed in a fitting — ..... A1-10

**Customer Maintenance Parts List (ISC40□J, ISC40F□J) ..... CMPL 12D06B02-01E**

**Customer Maintenance Parts List (ISC40□, ISC40F□ Style: S2) .....  
..... CMPL 12D06A02-03E**

**Customer Maintenance Parts List (ISC40□, ISC40F□ Style: S1) .....  
..... CMPL 12D06A02-02E**

**Customer Maintenance Parts List (ISC40□, ISC40F□ Delivered before 1998).....  
..... CMPL 12D06A02-02EA**

**Revision Record ..... i**

# 1. Introduction

## 1.1 Features

The model ISC40□J inductive conductivity detector is designed for use with the model ISC202/ISC402G, ISC450G transmitter/converter. This revolutionary conductivity measuring system features  $\pm 0.5\%$  accuracy over a wide range of conductivity values ( $1\mu\text{S}/\text{cm}$  to  $1,999\text{ mS}/\text{cm}$ ) and process temperatures ( $-10$  to  $130\text{ }^\circ\text{C}$ ,  $-10$  to  $105\text{ }^\circ\text{C}$  for ISC40SJ-TT) without changing cell constant or recalibration.

The model ISC40□J sensor is rugged steel-backed sensor encapsulated with the highest quality engineering plastic known today (Victrex PEEK) for long service life in both abrasive and chemically corrosive processes.

The stainless steel mounting thread and the Viton gasket allow safe and reliable installation. The long insertion depth allows for installation of the sensor either by a bulkhead mounting through a flange or tank wall, or by using one of the process adapter kits (e.g. for flow-through or immersion service).

The large bore, greater than  $16\text{ mm}$ , gives long-term stability, preventing measuring errors caused by coating or plugging. The large bore also offers fast response even at low flow rates.

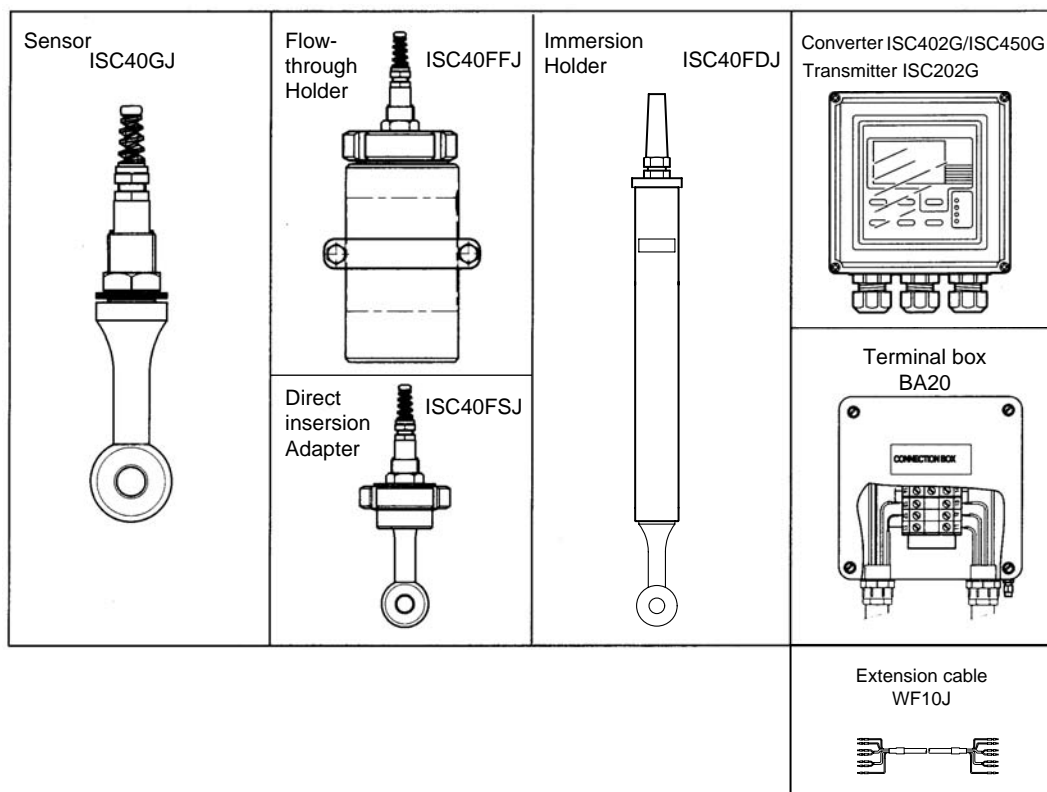
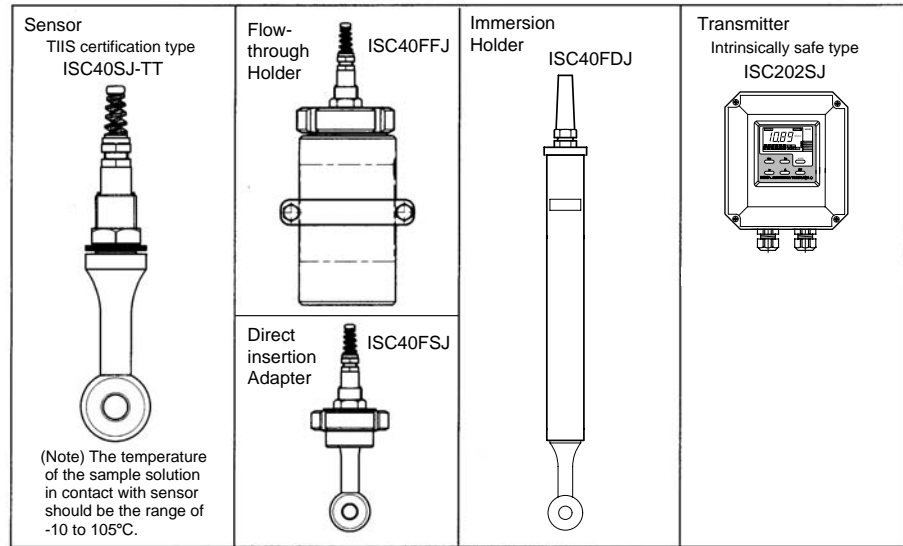

Fig01.eps

**Figure 1.1 Non-explosionproof System**



F1.1E.eps

**Figure 1.2 Explosionproof System**

## 1.2 Measurement principle

Contrary to contact electrode conductivity, the EXA ISC series analyses the conductivity without any contact between electrodes and process fluid. The measurement is based on inductive coupling of 2 ring transformers (Toroids) by the liquid.

The converter supplies a reference voltage at a high frequency to the "drive coil". The core of this coil is of a high permeability magnetic material, and a strong magnetic field is generated in the toroid.

The liquid passes through the hole in the toroid and can be considered as a "one turn" secondary winding.

The magnetic field will induce a voltage in this secondary winding. The induced current in the liquid winding is proportional to this voltage and the conductance of the liquid "one turn winding" is according to Ohm's law.

The conductance (1/R) is proportional to the specific conductivity and a constant factor that is determined by the geometry of the sensor (length divided by surface area of the hole in the toroid) and the installation of the sensor.

There are 2 toroids mounted in the "doughnut" shaped sensor. The liquid also flows through the second toroid and therefore the liquid turn can be considered as a primary winding of the second ring transformer.

The current in the liquid will create a magnetic field in the second toroid. The induced voltage being the result of this magnetic field can be measured as an output.

The output voltage of this "receive coil" is therefore proportional to the specific conductivity of the process liquid.

### Inductive conductivity measurement principle

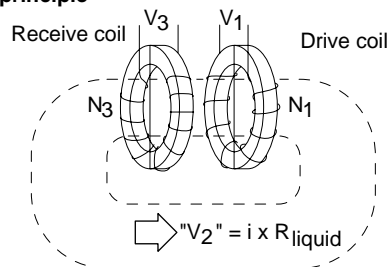

F1.2E.eps

**Figure 1.3 Measurement Principle**

## 2. Specifications

### 2.1 General Specifications

#### 2.1.1 ISC40□J Inductive Conductivity Sensor

Compatibility	: ISC40GJ is compatible with ISC202G Inductive Conductivity Transmitter and ISC402G/ISC450G Converter. ISC40SJ-TT is compatible with ISC202SJ Inductive Conductivity Transmitter.
Measurement Range	: 1 $\mu$ S/cm to 1999 mS/cm
Output Span	: Min. 100 $\mu$ S/cm ; Max. 1999 mS/cm
Process Temperature	: -10 to 130°C for continuous exposure. -10 to 105°C for ISC40SJ-TT. Suitable for steam-sterilisable applications. (Notes 1 and 2)
Process Pressure	: Pressure resistance 2 MPa max. (Note 1)
Process Flow Volume	: Max. 5 m/s
Wetted materials	
Sensor	: PEEK (polyether ether ketone)
Gaskets	: Viton (fluorine rubber)
Adapter (additional machining)	: SUS316, PVC or PVDF
Non-wetted materials	
Sensor Screws	: SUS304
Retaining Nuts	: SUS304
Cables	: Weatherproof vinyl
Process Connection	: Mounting with G3/4 screw at top of Sensor, or connection using process adapter or holder (flow-through or submersion type)
Process Adapter	: JIS 10K 50 RF flange (Material: SUS316) JIS 10K 50 FF flange (Material: PVC or PVDF) DIN PN16 DN50 flange (Material: SUS316) ANSI Class150 2 flange (Material: SUS316) Screw-in adapter (R2 screw Material: Can be selected from SUS316, PVC or PVDF)
Cable Length	: 5 m, 10 m, 15 m, 20 m Extension cable of up to 50 m can be used. (detector cable and extension cable)
Dimensions	: Refer to 2.3, "External Dimensions".
Weight	: Sensor Approx. 0.6 kg

Note 1: The process temperature and pressure differ depending upon the adapter or holder used.

Note 2: The temperature compensation range of the transmitter is between -10 and 130° C

Note 3: Do not submerge the sensor itself in process water, as the seams between the mold and the metal of the sensor are not waterproof. Since a temperature sensor is imbedded in the PEEK molded sensor, its response speed is not fast, Install another temperature sensor if necessary.

#### ISC40SJ-TT Intrinsically safe type sensor

TIIS certification sensor should be used with ISC202SJ

Protection Concept and Adapter Group: Ex ia IIC T4

Intrinsic safe rating:

Ui=14.4 V, Ii=20 mA, Pi=190 mW, Li=28.6 mH,

Ci=0.2  $\mu$ F

Environment and operational conditions

The temperature of the sample solution in contact with sensor should be the range of -10 to 105°C.

### 2.1.2 ISC40FDJ Immersion Holder

Process Temperature : Max. 80 ° C  
Process Pressure : 200 kPa at 20 ° C, 100 kPa at 80° C  
Materials Exposed to Process Liquid : Holder: Heat resistance PVC or SUS316  
O-rings : Fluorine rubber (Viton) (option)  
Fixing flange : PP or SUS316  
Mounting : Fixing flange mounting (option)  
DIN PN10 DN50 (ANSI Class 150 2 with bolt holes): Material PP  
JIS 10K 50 RF : Material SUS316  
JIS 2-inch pipe mounting (option) Mounting bracket : Material, zinc-plated steel

### 2.1.3 ISC40FFJ Flow-through Holder

Process Temperature : ISC40FFJ-SA, -SJ : Max. 150°C  
ISC40FFJ-PA, -PJ : Max. 100°C  
ISC40FFJ-FA, -FJ : Max. 130°C  
Process Pressure: ISC40FFJ-SA, -SJ : Max. 1.0 MPa at 150° C  
ISC40FFJ-SA, -PJ : Max. 0.6MPa at 20°C ; Max. 0.1 MPa at 100° C  
ISC40FFJ-FA, -FJ : Max. 1.0MPa at 20°C ; Max. 0.1 MPa at 130° C  
Materials Exposed to Process Liquid :  
ISC40FFJ-SA, -SJ : SUS316  
ISC40FFJ-PA, -PJ : Polypropylene  
ISC40FFJ-FA, -FJ : PVDF  
O-ring : Fluorine rubber (Viton) or ethylene propylene rubber  
Materials Not Exposed to Process Liquid :  
Nuts : SUS304  
(option) Mounting Bracket : SUS304  
(option) Loose flange adapter : SUS304  
Process Connection : 1/2 NPT or Rc 1/2  
(option) DIN PN10 DN25 flange  
(option) JIS 10K 25 RF flange

#### CAUTION



Select the material of wetted parts with careful consideration of process characteristics. Inappropriate selection may cause leakage of process fluids, which greatly affects facilities. Considerable care must be taken particularly in the case of strongly corrosive process fluid such as hydrochloric acid, sulfuric acid, hydrogen sulfide, and sodium hypochlorite. If you have any questions about the wetted part construction of the product, be sure to contact Yokogawa.

### 2.1.4 ISC40FSJ Direct Insertion Adapters

Process Temperature : ISC40FSJ-STWJ : Max. 110° C  
 ISC40FSJ-SCWJ, -SCSJ : Max. 150° C  
 ISC40FSJ-PCS J : Max. 100° C  
 ISC40FSJ-FCSJ : Max. 130° C

Process Pressure :

ISC40FSJ-STWJ : Max. 1.0MPa at 110°C  
 ISC40FSJ-SCWJ, -SCSJ : Max. 1.0 MPa at 150°C  
 ISC40FSJ-PCSJ : Max. 0.6MPa at 20°C; Max. 0.1 MPa at 100°C  
 ISC40FSJ-FCSJ : Max. 1.0MPa at 20°C ; Max. 0.1 MPa at 130°C

Materials Exposed to Process Liquid :

ISC40FSJ-STWJ : SUS316L, silicone rubber  
 ISC40FSJ-SCWJ, -SCSJ : SUS316, fluorine rubber  
 ISC40FSJ-PCSJ : Polypropylene, fluorine rubber  
 ISC40FSJ-FCSJ : PVDF, fluorine rubber

Materials Not Exposed to Process Liquid :

ISC40FSJ-STWJ : IDF 3 inch clamp: SCS13  
 ISC40FSJ-SCWJ, -SCSJ, -PCSJ, -FCSJ : Fixing nut : SUS304

Process Connection :

ISC40FSJ-STWJ : IDF 3 inch clamp welded ferrule  
 ISC40FSJ-SCWJ : Welded socket  
 ISC40FSJ-SCSJ, -PCSJ, -FCSJ : R2 screw-in connection

### 2.1.5 BA20 Junction Terminal Box

Use when the Inductive conductivity transmitter/converter is installed separately at a distance greater than the ISC40□J sensor's cable length.

Ambient Temperature: -10 to 55° C  
 Construction: Conforms to IP54  
 Case Material: Aluminum alloy casting  
 Electrical Connection Point: Two electrical inlets, PG13.5 cable gland  
 Weight : 2 kg  
 (Note) BA20 can not be used with ISC40SJ-TT.

### 2.1.6 WF10J Extension Cable

Number of Conductors : 6 (without shield)  
 Finished O.D. : 7.7 mm  
 Termination Dedicated cable termination  
 Material : Weatherproof vinyl  
 (Note) WF10J can not be used with ISC40SJ-TT.

## 2.2 Model and suffix codes

### 2.2.1 Inductive Conductivity Sensor

Non-explosionproof type

[Style: S1]

Model	Suffix code	Option code	Description
<b>ISC40GJ</b>	-----	-----	General purpose inductive conductivity sensor
Construction	<b>-GG</b>	-----	Standard type
Temperature sensor	<b>-T1</b>	-----	Pt1000 *1
	<b>-T3</b>	-----	Thermistor
Cable length, cable end type	<b>-05</b>	-----	5 m (pin terminals)
	<b>-10</b>	-----	10 m (pin terminals)
	<b>-15</b>	-----	15 m (pin terminals)
	<b>-20</b>	-----	20 m (pin terminals)
	<b>-Y1</b>	-----	5 m (M3 ring terminals) *3
	<b>-Y2</b>	-----	10 m (M3 ring terminals) *3
	<b>-Y3</b>	-----	15 m (M3 ring terminals) *3
Option Adapter	<b>/SFJ</b>		JIS 10K 50 RF Flange SUS316
	<b>/PFJ</b>		JIS 10K 50 FF Flange PVC
	<b>/FFJ5</b>		JIS 10K 50 FF Flange PVDF
	<b>/SFD</b>		DIN PN16 DN50 Flange SUS316
	<b>/SFA</b>		ANSI Class 150 2 Flange SUS316
	<b>/SSG</b>		R2 screw-in adapter SUS316
	<b>/PSG</b>		R2 screw-in adapter PVC
O-ring, gasket	<b>/FSJ</b>		R2 screw-in adapter PVDF
	<b>/EP</b>		Ethylene propylene rubber O-ring or gasket *2

\*1 Choose thermistor (-T3) only, when connecting with ISC200G.

\*2 For use in highly alkaline solutions, be sure to check the process conditions and contact us.

\*3 Used for connection to ISC450G, ISC202G/TB.

T2.1E.eps

Explosionproof type

[Style: S2]

Model	Suffix code	Option code	Description
<b>ISC40SJ</b>	-----	-----	Intrinsic safe inductive conductivity sensor
Construction	<b>-GG</b>	-----	TIIS certification type (for ISC200S)
	<b>-TT</b>	-----	TIIS certification type (for ISC202SJ)
Temperature sensor	<b>-T1</b>	-----	Pt1000 *1
	<b>-T3</b>	-----	Thermistor
Cable length, cable end type	<b>-05</b>	-----	5 m (pin terminals)
	<b>-10</b>	-----	10 m (pin terminals)
	<b>-15</b>	-----	15 m (pin terminals)
	<b>-20</b>	-----	20 m (pin terminals)
Option Adapter	<b>/SFJ</b>		JIS 10K 50 RF Flange SUS316
	<b>/PFJ</b>		JIS 10K 50 FF Flange PVC
	<b>/FFJ5</b>		JIS 10K 50 FF Flange PVDF
	<b>/SFD</b>		DIN PN16 DN50 Flange SUS316
	<b>/SFA</b>		ANSI Class 150 2 Flange SUS316
	<b>/SSG</b>		R2 screw-in adapter SUS316
	<b>/PSG</b>		R2 screw-in adapter PVC
O-ring, gasket	<b>/FSJ</b>		R2 screw-in adapter PVDF
	<b>/EP</b>		Ethylene propylene rubber O-ring or gasket *2

\*1 Choose thermistor (-T3) only, when connecting with ISC200S.

\*2 For use in highly alkaline solutions, be sure to check the process conditions and contact us.

(Note) "TIIS Certification" as a certified explosion approval from the Technology Institution of Industrial Safety.

T2.1E.eps

## Accessories

Part No.	Description
K9414EF	O-ring (large, 40.64 mm I.D) (Viton)
K9414EA	O-ring (large, 40.64 mm I.D) (EPDM, when option code "/EP" specified)
K9414EG	O-ring (small, 26.57 mm I.D) (Viton)
K9414EB	O-ring (small, 26.57 mm I.D) (EPDM, when option code "/EP" specified)
K9414DS	Gasket (Viton)
K9414DA	Gasket (EPDM, when option code "/EP" specified)

T2.2E.EPS

## 2.2.2 Immersion Holder

Model	Suffix code	Option code	Description
ISC40FDJ	-----	-----	Immersion holder
Material	-V	-----	Immersion probe C-PVC
	-S	-----	Immersion probe SUS316
Pipe length	-10	-----	1.0 m
	-15	-----	1.5 m
	-20	-----	2.0 m
Option	Flange	/FA	DIN PN10 DN50 Flange PP (Can be selected for -V) (ANSI Class 150 2 with Bolt-holes)
		/FBJ	JIS 10K 50 RF Flange SUS316
	Mounting hardware	/MS1	Mounting hardware for immersion type : 1 set
		/MS2	Mounting hardware for immersion type : 2 set
	O-ring	/EP	Ethylene propylene rubber *

\* For use in highly alkaline solutions, be sure to check the process conditions and contact us.

T2.3E.eps

## 2.2.3 Flow-through Holder

Model	Suffix code	Option code	Description
ISC40FFJ	-----	-----	Flow-through holder
Material	-PJ	-----	Rc1/2 Polypropylene (PP)
	-PA	-----	1/2NPT female Polypropylene (PP)
	-SJ	-----	Rc1/2 SUS316
	-SA	-----	1/2NPT female SUS316
	-FJ	-----	Rc1/2 PVDF
	-FA	-----	1/2NPT female PVDF
Option	Mounting hardware	/MS	Wall/pipe mounting hardware for SUS holder
		/MP	Wall/pipe mounting hardware for PP or PVDF holder
Flange	/FSJ2		JIS 10K 25 RF Flange SUS316 (for -SJ) *1
	/FS2		DIN PN10 DN25 Flange SUS316 (for -SA)*1
	/FPJ2		JIS 10K 25 RF Flange PP (for -PJ)*1
	/FP2		DIN PN10 DN25 Flange PP (for -PA)*1
	/FFJ2		JIS 10K 25 RF Flange PVDF (for -FJ)*1
	/FF2		DIN PN10 DN25 Flange PVDF (for -FA)*1
O-ring	/EP		Ethylene propylene rubber *2
Polishing	/POL		Polished surface *3

\*1 All flanges are adjustable. Each material in the above description represents the one of wetted part of the adjustable flange which itself is made of SUS304.

\*2 For use in highly alkaline solutions, be sure to check the process conditions and contact us.

\*3 Option in case of SUS316 material.

T2.4E.eps

## 2.2.4 Direct Insertion Adapter

Model	Suffix code	Option code	Description
ISC40FSJ	-----	-----	Direct insertion adapter
Process connection	-PCSJ	-----	R2 screw-in coupling PP
	-SCWJ	-----	Coupling welded SUS316
	-SCSJ	-----	R2 screw-in coupling SUS316
	-STWJ	-----	IDF 3 inch clamp SUS316L
	-FCSJ	-----	R2 screw-in coupling PVDF
Option		/EP	Ethylene propylene rubber *

T2.5E.eps

\* For use in highly alkaline solutions, be sure to check the process conditions and contact us.

## 2.2.5 Terminal Box

Model	Suffix code	Option code	Description
BA20	-----	-----	Terminal box
Option		/YT	M3 screw terminals *1

(Note) Pin terminals is supplied when option code is'nt specified.

BA20 can not be used with ISC40SJ-TT.

(\*1) Use to connect with ISC450G, ISC202G/TB.

T2.6E.eps

## 2.2.6 Extension Cable

Model	Suffix code	Option code	Description
WF10J	-----	-----	Extension cable
Cable end	-F	-----	Pin terminals
	-Y	-----	M3 ring terminals *1
Cable length	-05	-----	5 m
	-10	-----	10 m
	-20	-----	20 m
	-30	-----	30 m
	-40	-----	40 m

(\*1) Used for connection to ISC450G, ISC202G/TB.

(Note) The maximum extension cable length is 50 m including sensor cable length and can not be used with ISC40SJ-TT.

T2.7E.eps

## 2.3 External Dimensions

### 2.3.1 ISC40□J Inductive Conductivity Sensor

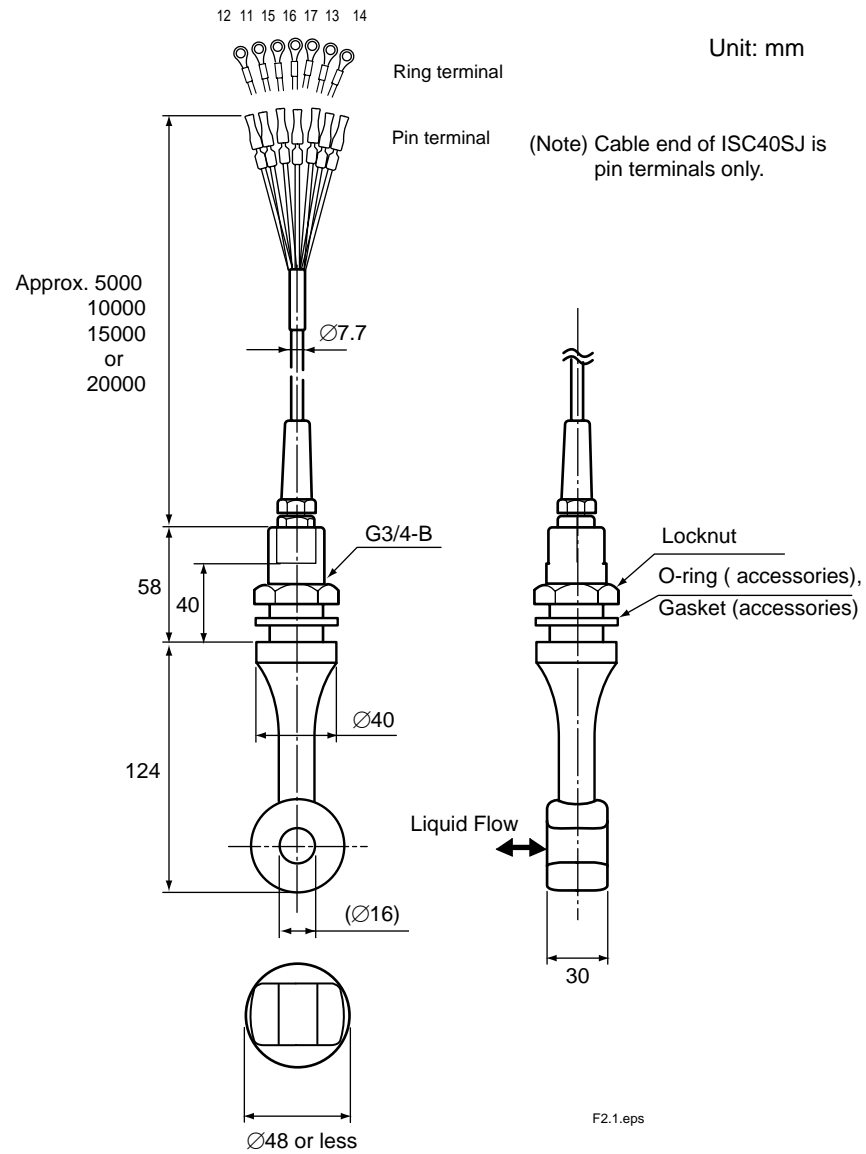
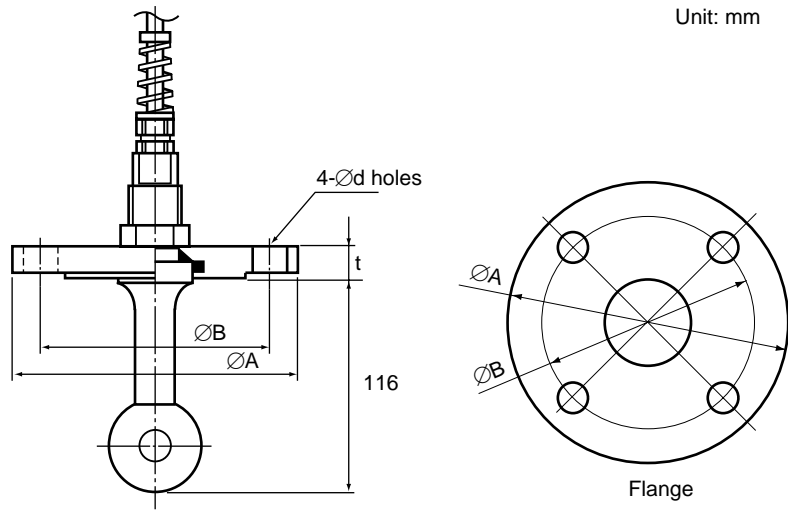

Figure 2.1

•Optional Flange Adapter

Unit: mm



Option Code	A	B	d	t	Material	Flange Rating	Weight (kg)
/SFJ	155	120	19	16	SUS316	JIS 10K 50 RF	Approx. 1.9
/PFJ	155	120	19	20	PVC	JIS 10K 50 FF	Approx. 0.5
/FFJ5	155	120	19	20	PVDF	JIS 10K 50 FF	Approx. 0.5
/SFD	165	125	18	18	SUS316	DIN PN16 DN50	Approx. 2.7
/SFA	152.4	120.6	19	19	SUS316	ANSI Class150 2	Approx. 3.0

F2.2E.eps

Figure 2.2

•Optional Screw-in Adapter

Unit : mm

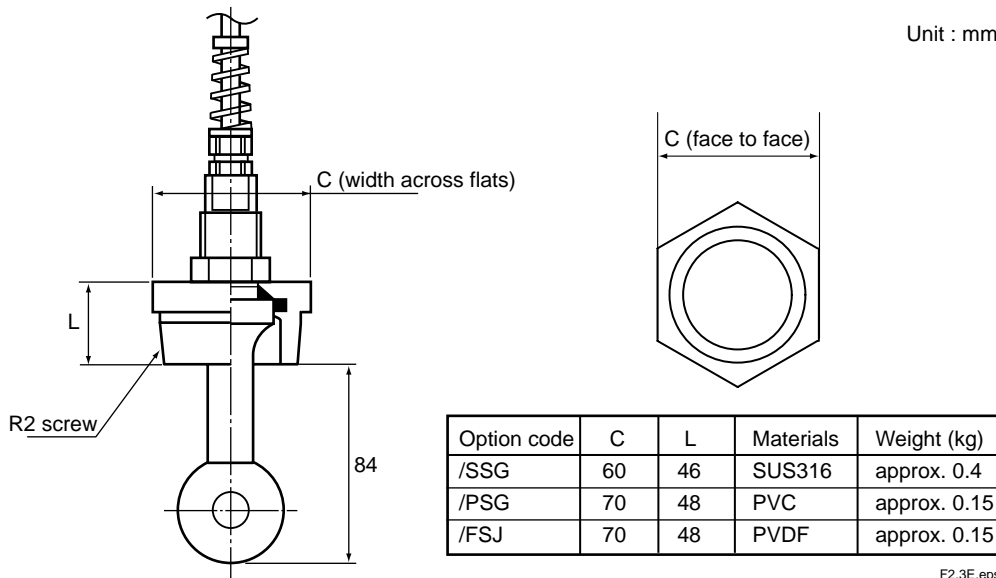

Option code	C	L	Materials	Weight (kg)
/SSG	60	46	SUS316	approx. 0.4
/PSG	70	48	PVC	approx. 0.15
/FSJ	70	48	PVDF	approx. 0.15

F2.3E.eps

Figure 2.3

2.3.2 ISC40FDJ Immersion Holder

Unit: mm

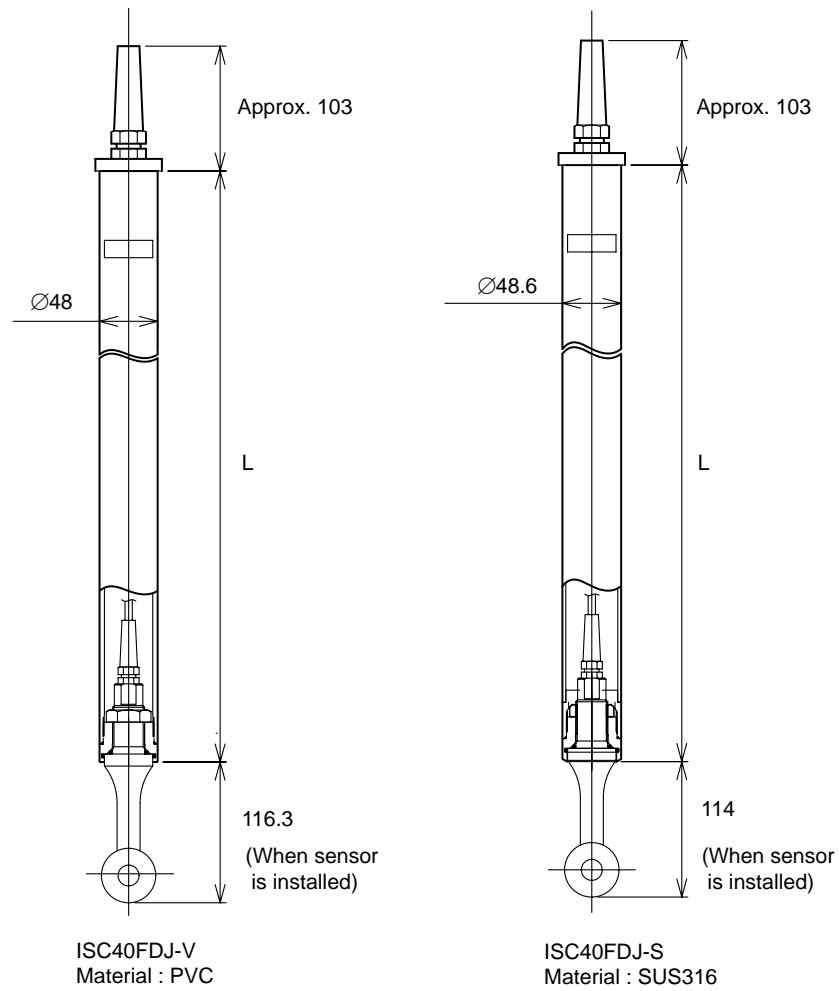

Model code	L	Weight (kg)
ISC40FDJ-V-10	1000	Approx. 0.9
ISC40FDJ-V-15	1500	Approx. 1.3
ISC40FDJ-V-20	2000	Approx. 1.7
ISC40FDJ-S-10	1000	Approx. 3.6
ISC40FDJ-S-15	1500	Approx. 5.2
ISC40FDJ-S-20	2000	Approx. 6.8

F2.4E.eps

Figure 2.4

### Fixing flange

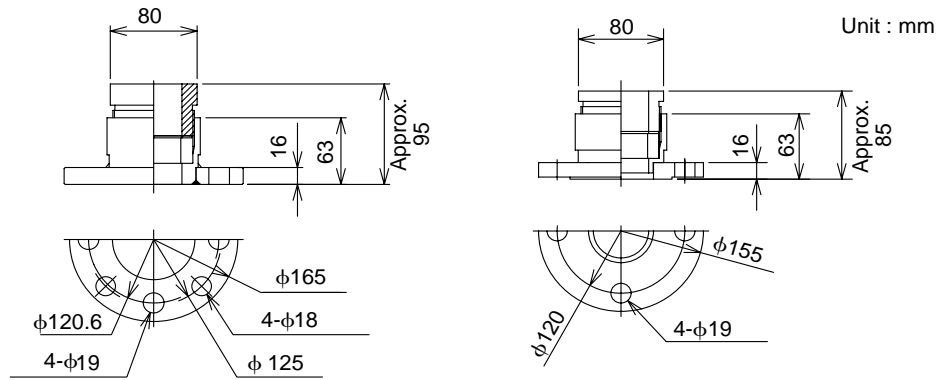

Option Code : /FA

DIN PN10 DN50 (Note)  
 (ANSI Class150 2 equ.)  
 Material : PP

Option Code : /FBJ

JIS 10K 50 RF (Note)  
 Material : SUS316

(Note) Only mating dimensions are according to flange standards.

F2.5E.eps

**Figure 2.5**

### Immersion holder mounting hardware : /MS1 or /MS2 option

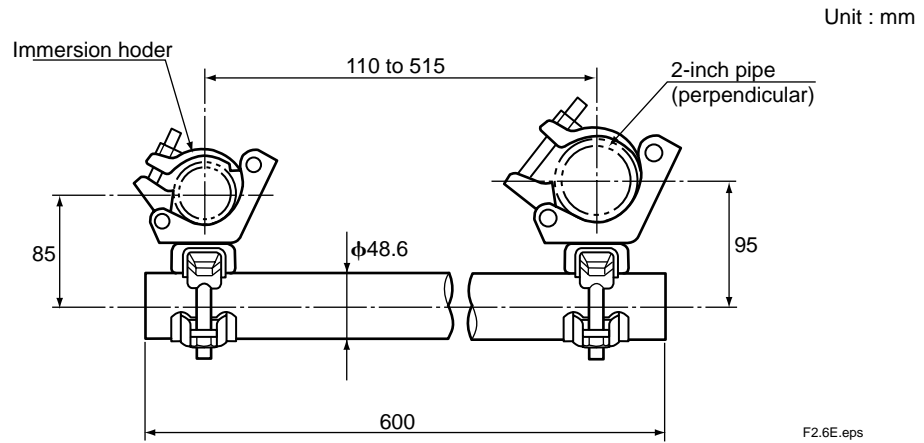

F2.6E.eps

**Figure 2.6**

2.3.3 ISC40FFJ Flow-through Holder

•Holder Material: SUS316 (ISC40FFJ-S□)

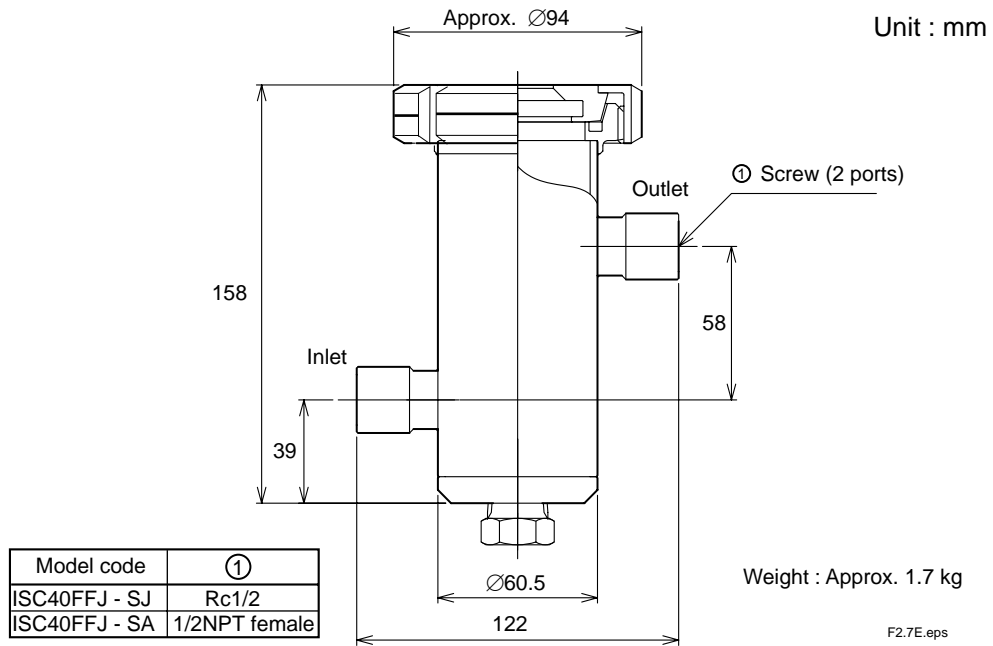

Figure 2.7

Mounting hardware when /MS option specified

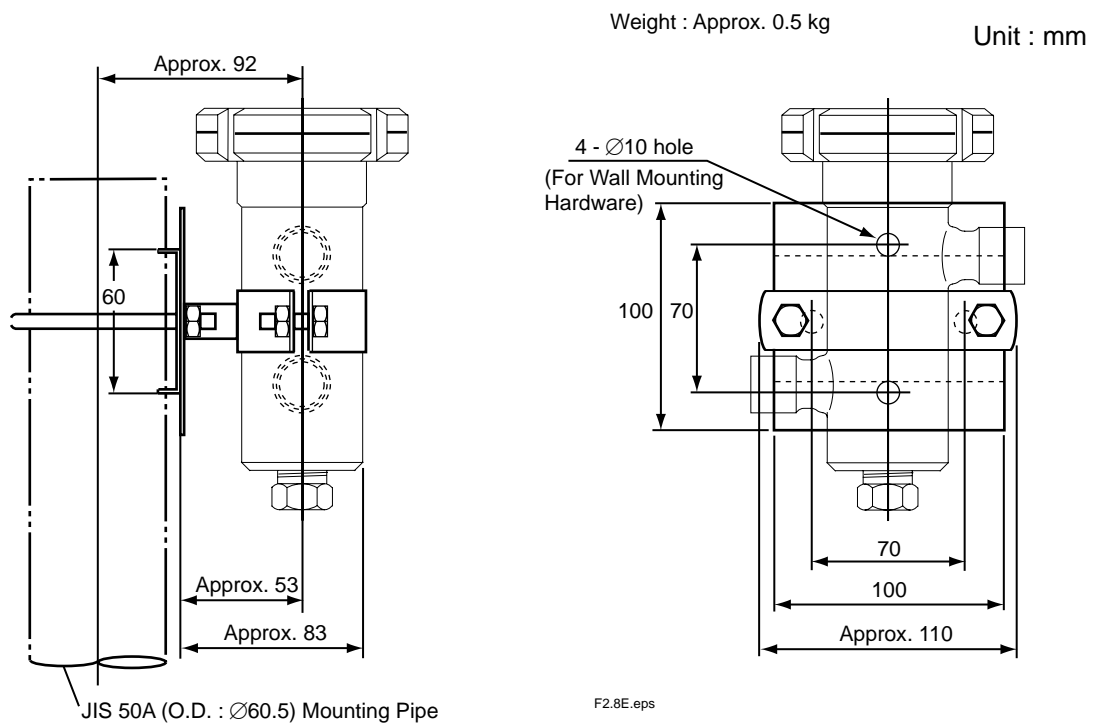
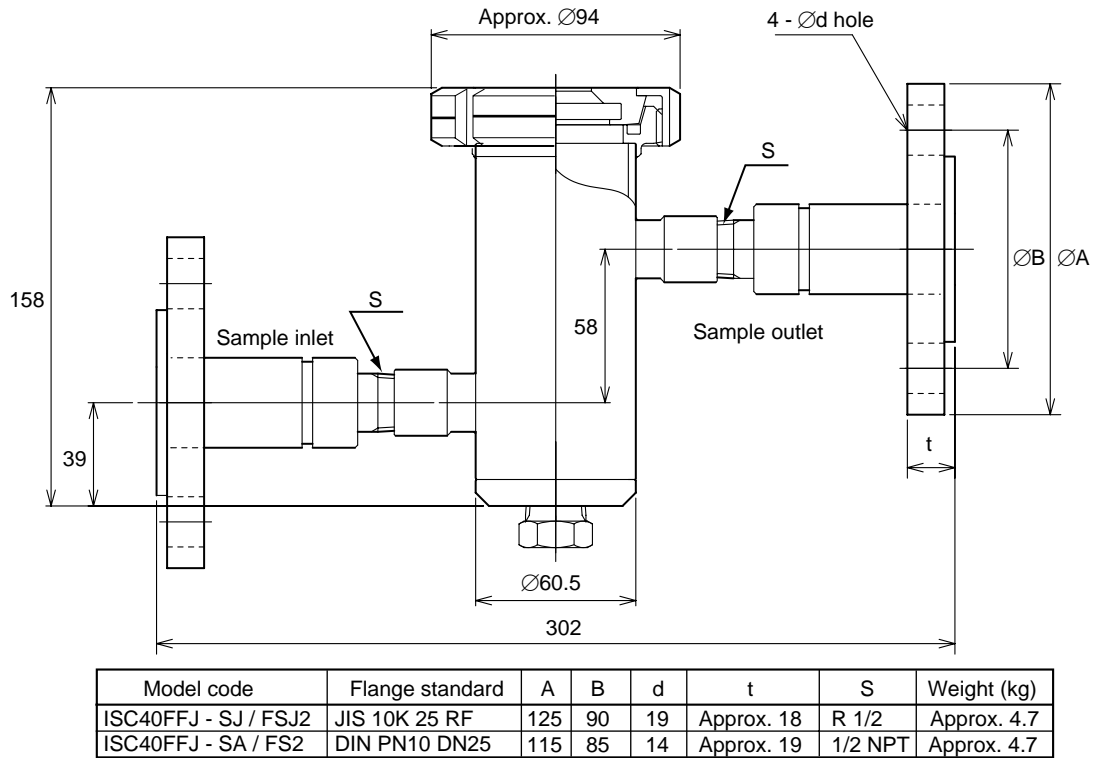

Figure 2.8

•Holder Material: SUS316 with flange (ISC40FFJ-S□/FS2, /FSJ2)

Unit: mm



F2.9E.eps

Figure 2.9

Mounting hardware when /MS option specific

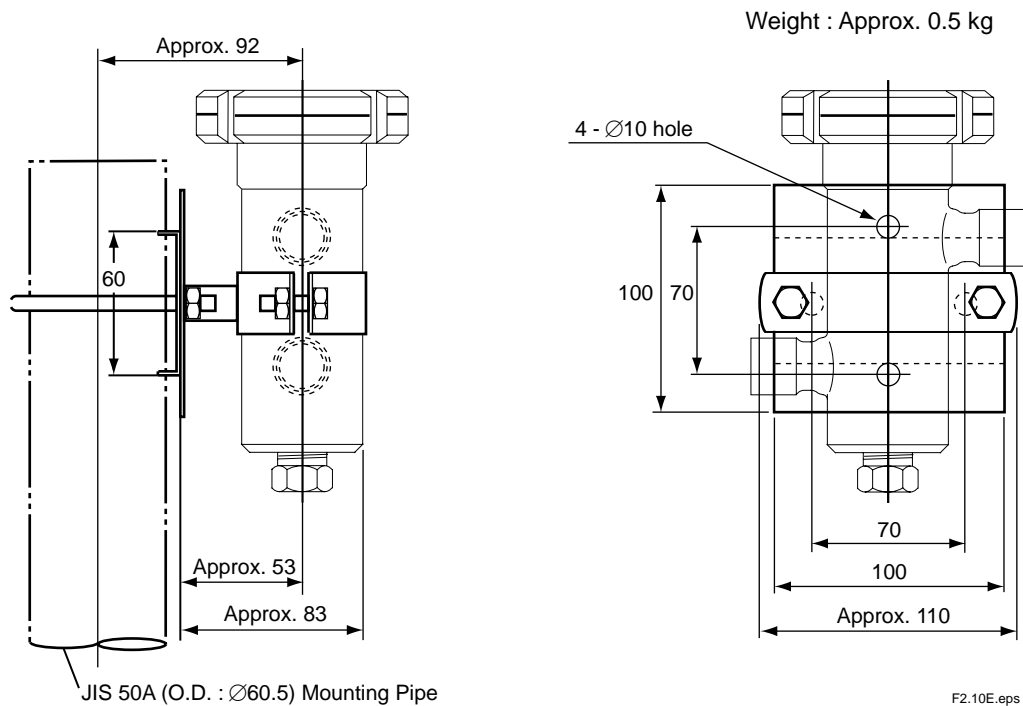

F2.10E.eps

Figure 2.10

•Holder Material: PP, PVDF (ISC40FFJ-P□, -F□)

Unit: mm

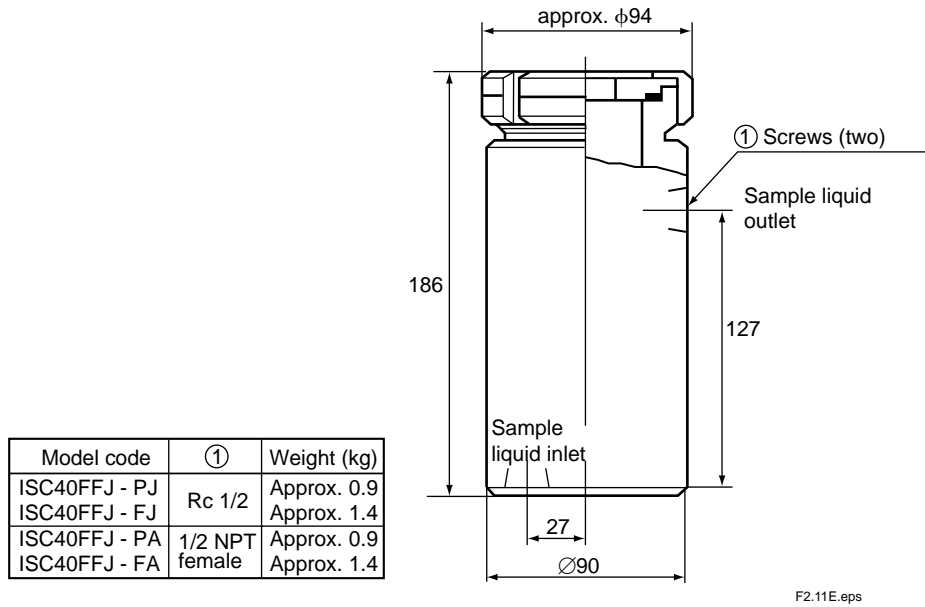

F2.11E.eps

Figure 2.11

Mounting hardware when /MS option specified

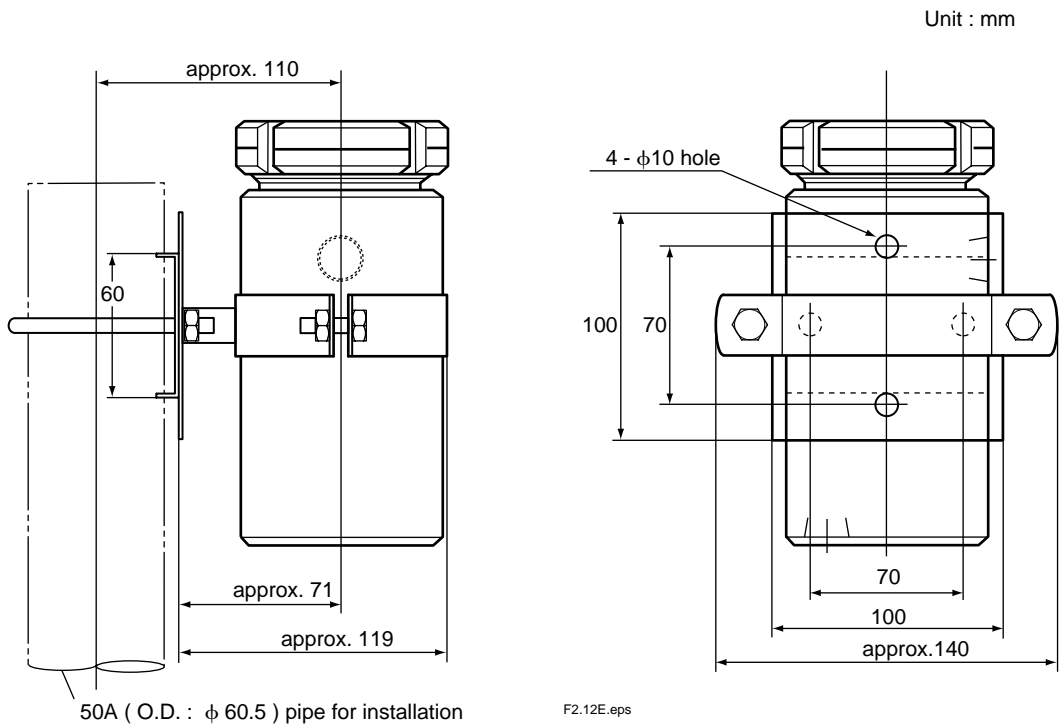

Unit : mm

F2.12E.eps

Figure 2.12

•Holder Material: PP, PVDF with flange (ISC40FFJ-P□, -F□)

Unit: mm

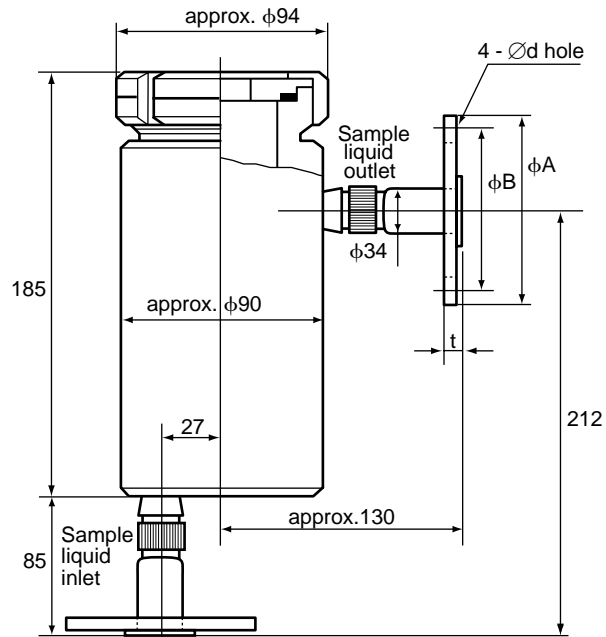

ISC40FFJ - PA, - PJ, -FA, -FJ / FP2, / FPJ2, / FF2, / FFJ2 (with flange) F2.13E.eps

Model code	Flange standard	A	B	d	t	Weight (kg)
ISC40FFJ - PJ / FPJ2	JIS 10K 25 RF	125	90	19	approx. 20	Approx. 3.2 kg
ISC40FFJ - FJ / FFJ2						Approx. 3.9 kg
ISC40FFJ - PA / FP2	DIN PN10 DN25	115	85	14	approx. 19	Approx. 3.2 kg
ISC40FFJ - FA / FF2						Approx. 3.9 kg

Figure 2.13

Mounting hardware when /MS option specified

Unit : mm

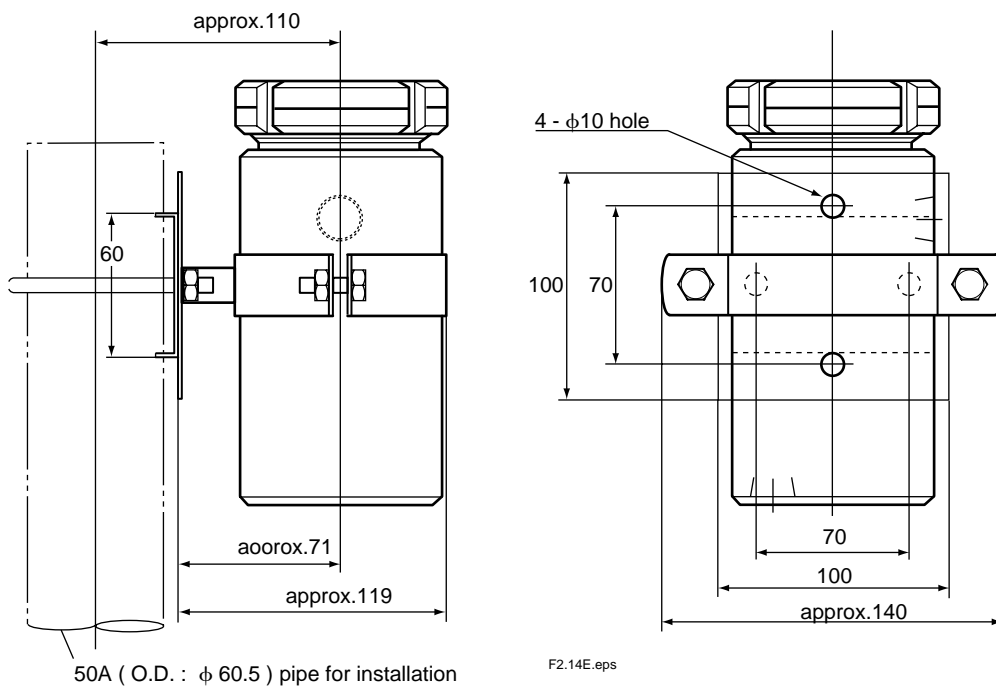

Figure 2.14

2.3.4 ISC40FSJ Direct Insertion Adapters

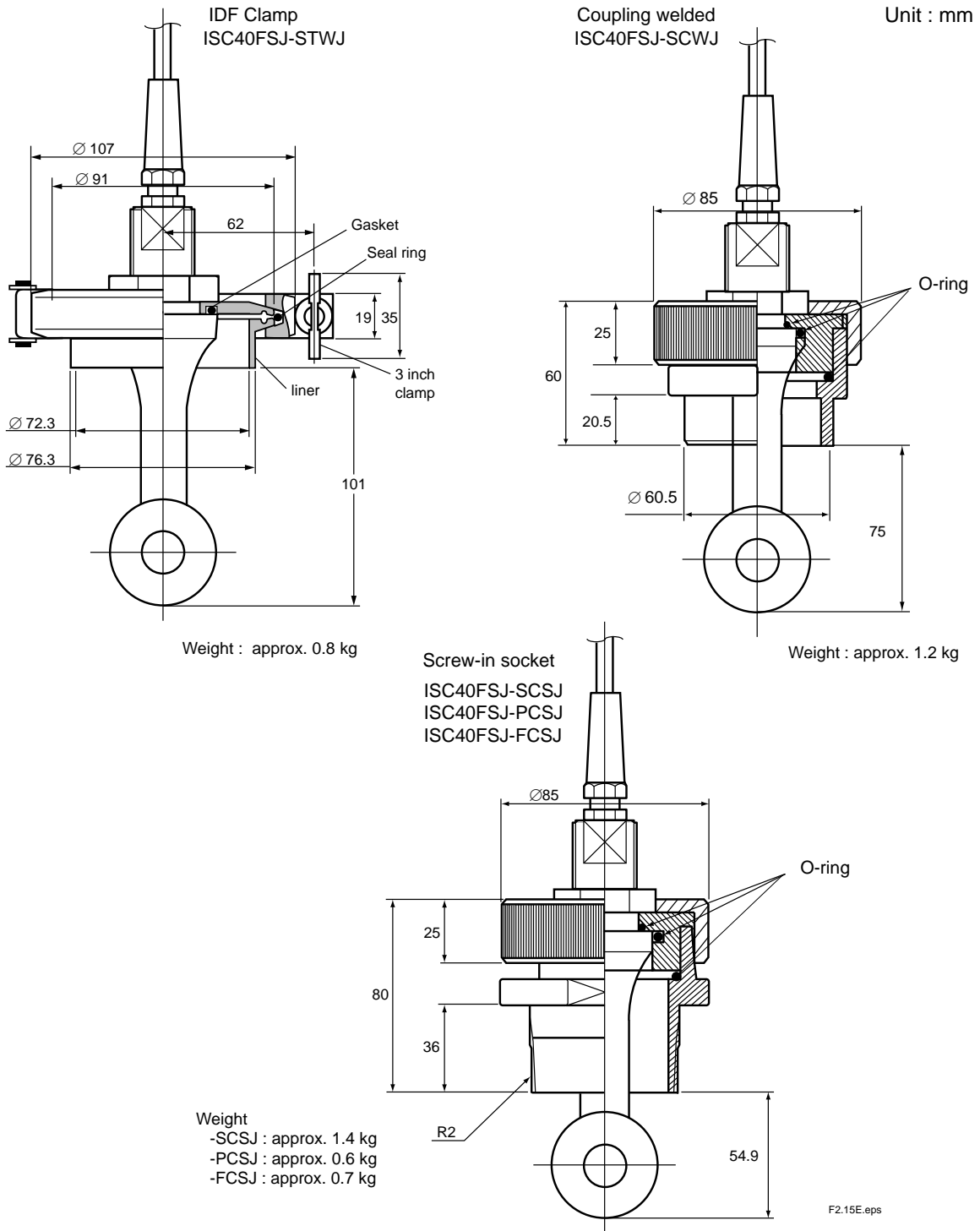

Figure 2.15

### 2.3.5 BA20 Junction Terminal Box

Unit: mm

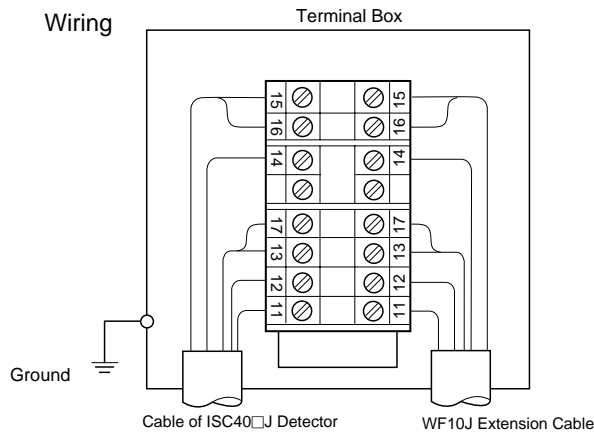
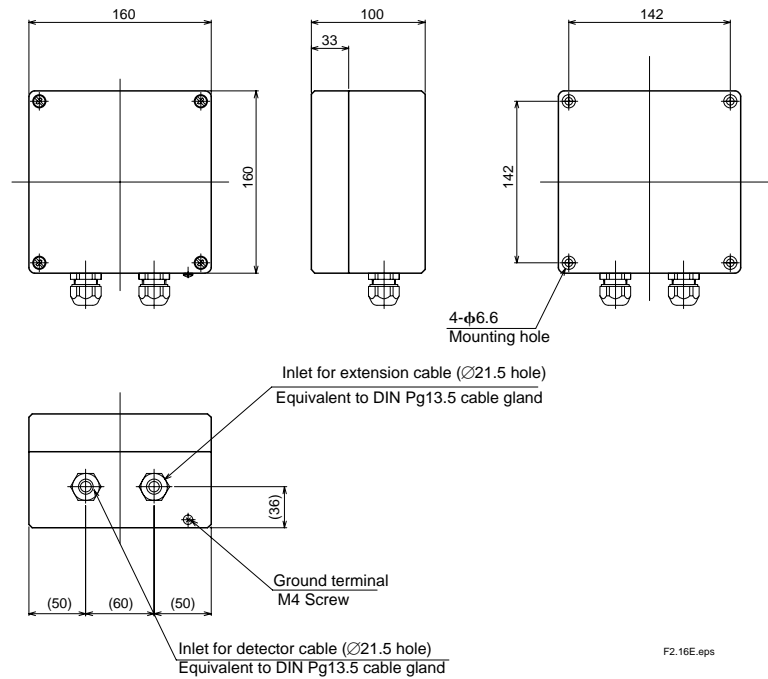

Figure 2.16

### 2.3.6 WF10J Extension Cable

Unit: mm

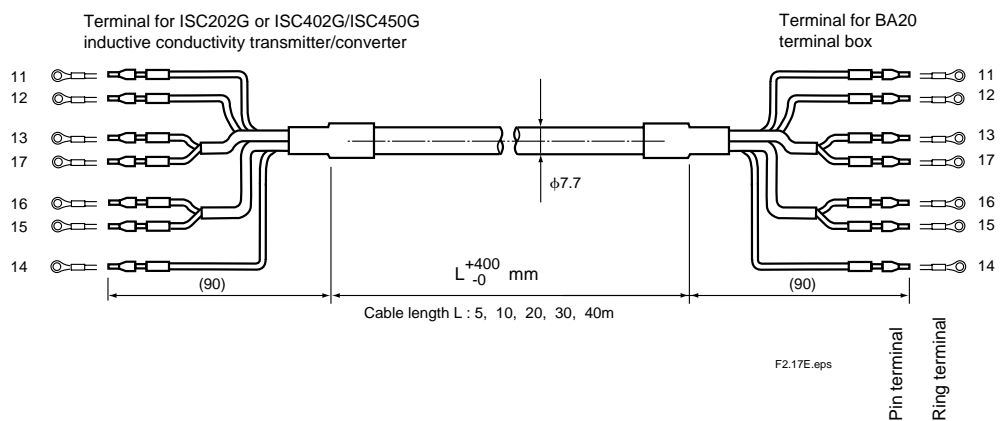

Figure 2.17

# 3. Installation and Wiring

## 3.1 Installation

### 3.1.1 Sensor Mounting

You can use the ISC40□J sensors with matching holders, ordered together with the sensors or separately. The holder mounting differs depending on whether gasket or O-ring seals are used. Refer to the appropriate parts of this manual, especially Sec. 3.2.1, for details.

Handling Cautions for ISC40□J

1. When tightening nuts on flanges and the like, be careful not to over-tighten, as described below.
2. When installing, ensure that gasket or O-ring seals are installed in the correct locations.

When flange mounting the ISC40□J Inductive Conductivity Sensors, the torque applied to the lock nut should be approx. 40 N.m (approx. 4 kgf.m). When tightening, as illustrated in Figure 3.1 (a), use a monkey wrench or the like on the flat surfaces to prevent the sensor from being turned. The flat surfaces on the bolts should be perpendicular to the flow direction (the hole in the donut should be parallel to the flow direction).

#### Approx. 40 N.m { approx. 4 kgf.m } tightening torque :

Use a monkey wrench of length about 300 mm for tightening the sensor mounting nuts (see Figure 3.1 (b)). Tighten using finger pressure on the end of the wrench.

#### CAUTION

1. If the tightening force is insufficient, liquid leaks may result; if too large then damage to the sensor may result.
2. If you try to align the sensor with the flow after tightening, then excessive force may be applied and the sensor damaged.

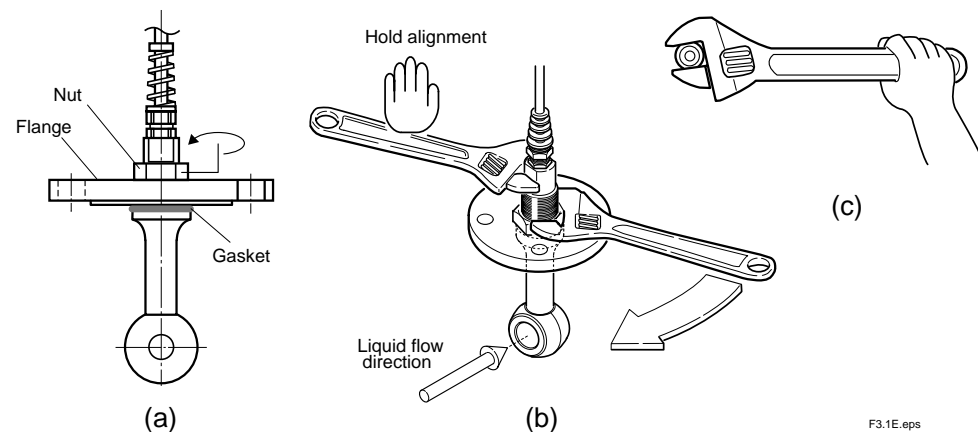
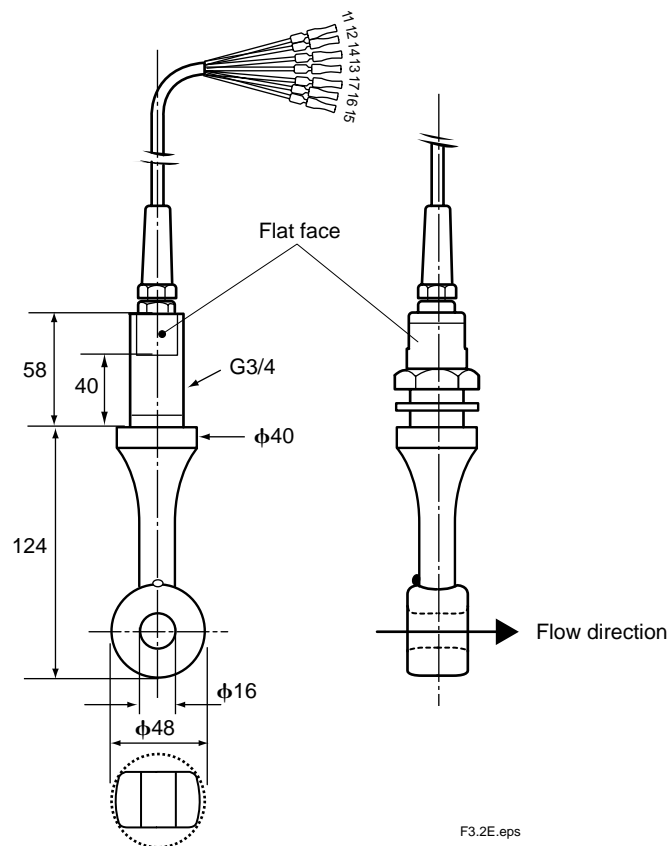

Figure 3.1 Sensor mounting

The ISC40□J inductive conductivity sensor is a donut shaped sensor. Install the sensor in such a way that the sensor hole is parallel to the flow (see Figure 3.2).



**Figure 3.2 Installation of Sensor**

Ensure that the sample liquid flows through the hole in the sensor. The sensor is provided with a gasket and retaining nut. This allows "bulkhead mounting" in a tank wall or standard flange through a hole with a 27-mm diameter (A). The insertion depth is 124 mm. Using a 20-mm size wrench, the sensor can be easily mounted and aligned.

The distance (d) between the sensor and the pipe wall should be more than 30 mm (refer to Figure 3.3).

The installation factor of the ISC40G/S is the ratio of the measured conductivity at the sensor and the specific conductivity of the solution. The unit is  $\text{cm}^{-1}$  just as the cell constant of a contact electrode system. An installation factor unique to each sensor is indicated on the label of the sensor cable. (The nominal value is  $1.88 \text{ cm}^{-1}$ .) This factor varies depending on materials of process piping and the distance between the doughnut sensor and process piping. If the distance (d) is less than 30 mm, sensor calibration is required before using the ISC40□J. From the calibration results, the ISC202G/ISC402G will calculate an installation factor corresponding to the installation conditions and use it for conductivity measurement (For details, refer to relevant instruction manual).

In case where sensor calibration is difficult to be conducted, enter the manually calculated installation factor into the ISC202G/ISC402G following the instructions below.

- When a sensor is installed in the standard stainless steel holder, ISC40FFJ-S:  
An installation factor decreases approximately 7 %.

Reduce the value indicated on the label of the sensor cable by 7 %, and then enter the result.

- When a sensor is installed in the standard polypropylene holder, ISC40FFJ-P:  
An installation factor increases approximately 1%.

Increase the value indicated on the label of the sensor cable by 1 %, and then enter the result.

- When a sensor is installed in long piping with a distance (d) between the sensor and piping, as shown in Figure 3.3:

The installation factor for pipe mounting (reference data when the nominal value is 1.88 cm<sup>-1</sup>) is shown in Figure 3.3. Divide the value indicated on the label of the sensor cable by 1.88 and then multiply the quotient by the value obtained from Figure 3.3. Enter the result to the ISC202G/ISC402G (For details, refer to relevant instruction manual).

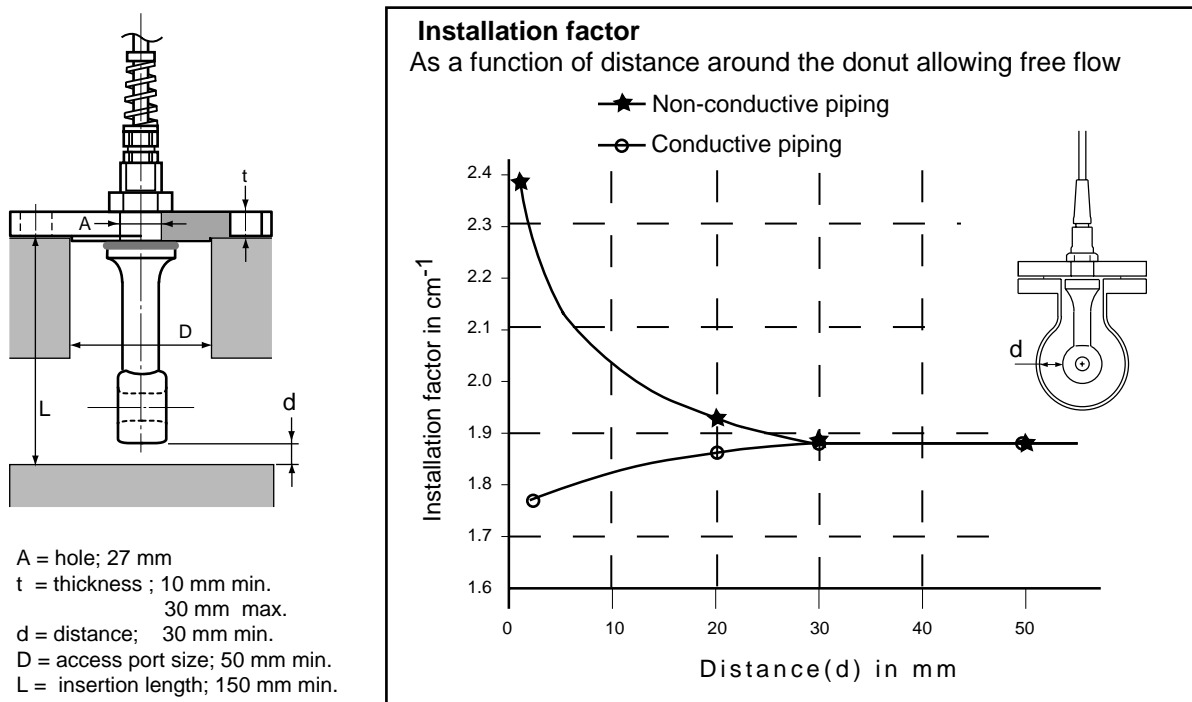

F3.3E.eps

**Figure 3.3 Example of Flange or Pipe Mounting, Installation Factor**

 **CAUTION**

Do not submerge the sensor itself in process water, as the seams between the mold and the metal of the sensor are not waterproof.

(1) Direct Insertion adapter

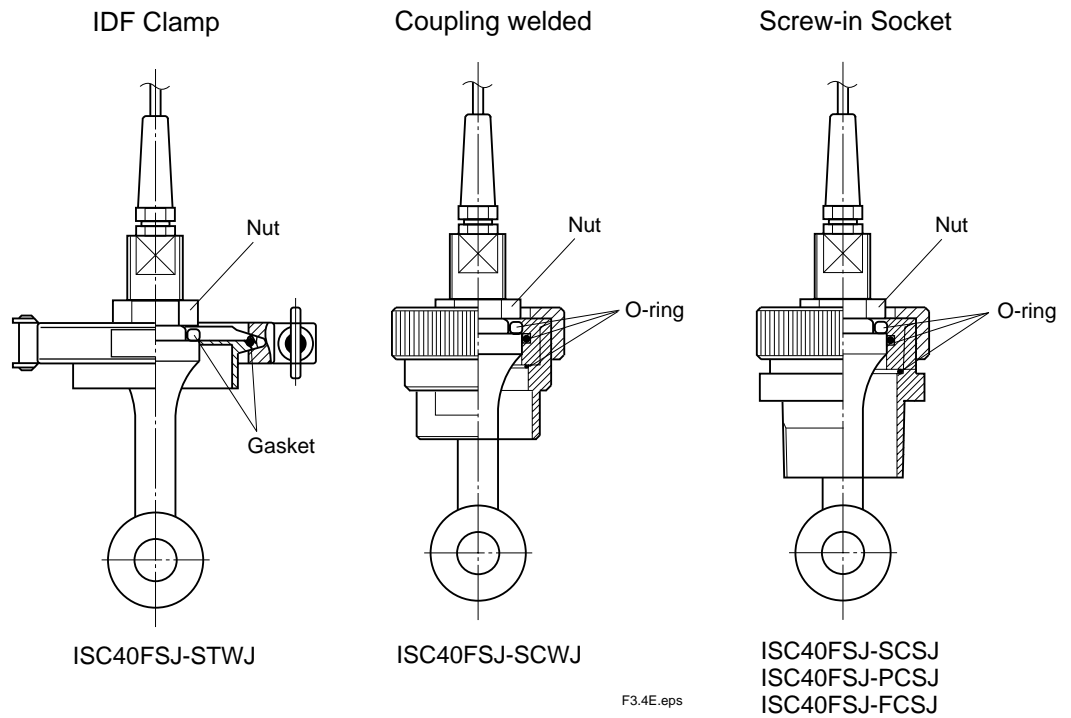

**Figure 3.4**

Install the ISC40FSJ direct insertion adapter on the wall, etc., on which the sensor is to be installed. Next, while referring to Sec. 3.2, install the sensor on the adapter. Refer to 2.3 "External Dimensions" for the dimensions of the adapter.

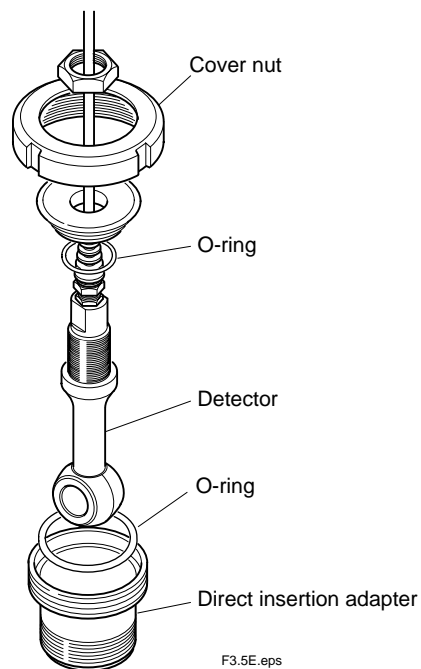

**Figure 3.5 Installing Sensor with adapter**

## (2) Direct flange mounting

There are two methods of installing the sensor, a method in which the sensor is directly screwed onto on the flange, and a method in which an adapter is first screwed onto the flange, then the sensor installed on the adapter. The latter method enables the direction of the sensor to be adjusted easily. Refer to 2.3 "External Dimensions".

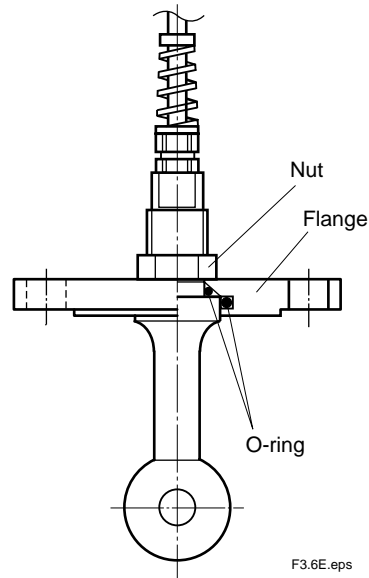

**Figure 3.6** Direct flange mounting

## (3) Installing a Screw-in adapter

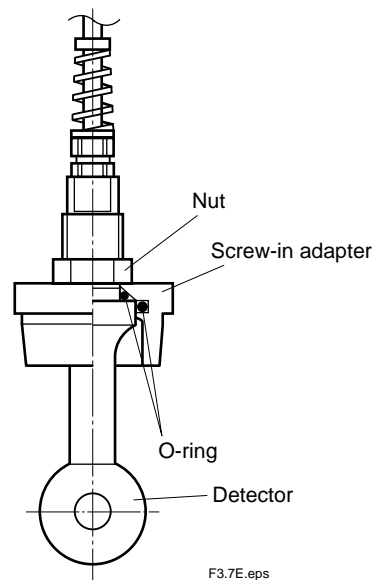

**Figure 3.7** Optional screw-in adapter

#### (4) Installing a Flow-through Holder

A flow-through holder is available in four types, as shown in the dimension drawing. Connect the process pipes in such a way that the sample flows in from the lower connection port and flows out from the upper connection port. Regarding the installation of the flow-through holder, if the pipes that are to be connected to the holder have adequate strength it is permissible to support the holder with the pipes, however from the viewpoint of safety it is recommended that you fix the holder to a wall or pipe using a dedicated mounting bracket. Check the type number and code that you specified when ordering the holder, compare these numbers with 2.3 "External Dimensions" and obtain a piping connection that matches them. Refer to Sec. 3.2 when installing the holder.

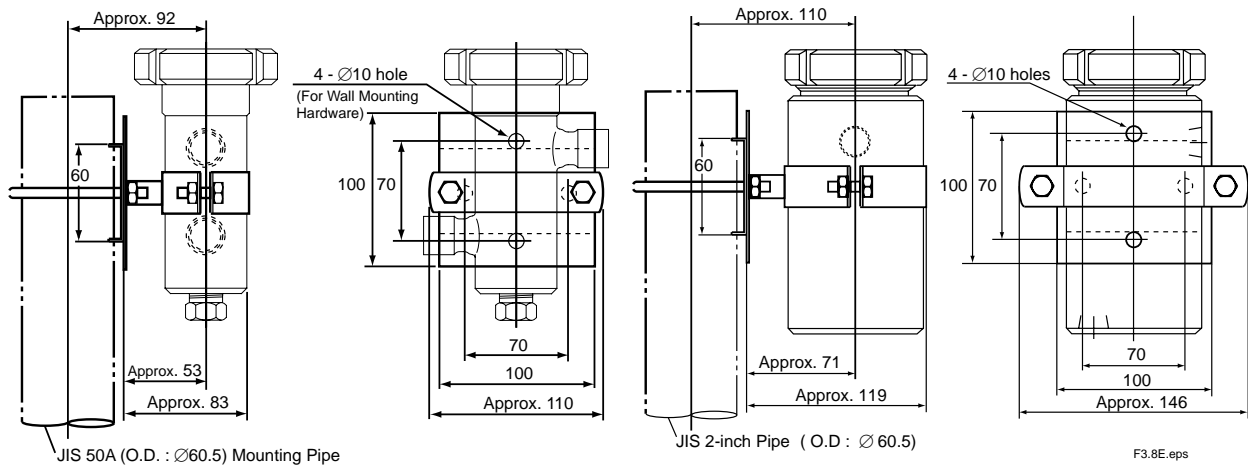

ISC40FFJ-S□

ISC40FFJ-P□

ISC40FFJ-F□

Figure 3.8 Flow-through holder

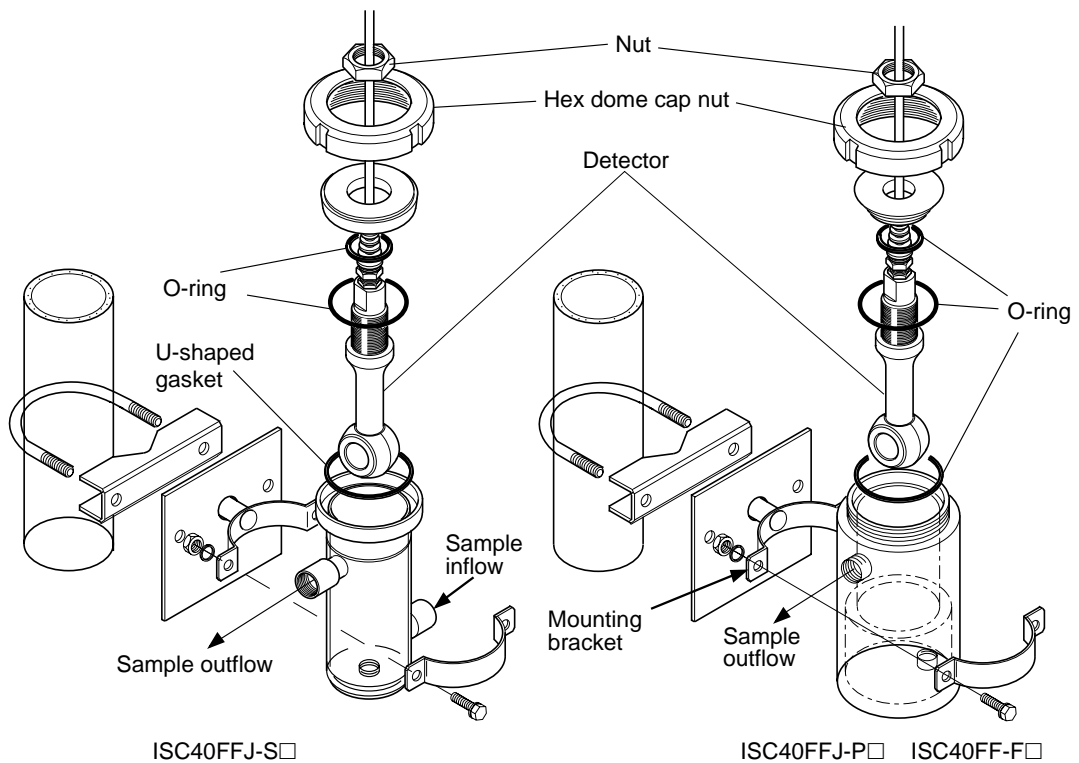

ISC40FFJ-S□

ISC40FFJ-P□ ISC40FF-F□

Figure 3.9 Example of Installing a Flow-through Holder

(5) Installing an Immersion Holder

Install an immersion holder in such a way that the sensor can be installed correctly in the measurement position. Install the holder at an adequate distance from the wall of the vessel to ensure that the measurement is not effected. Refer to Figure 3.10 when installing the sensor in a immersion holder. Install the immersion holder to a perpendicular pipe that has adequate strength (nominal diameter 50A) using a direct pipe connection piece so the sample liquid flows through the hole in the sensor (see Figure 3.10). Securely tighten the nut of each direct pipe connection piece.

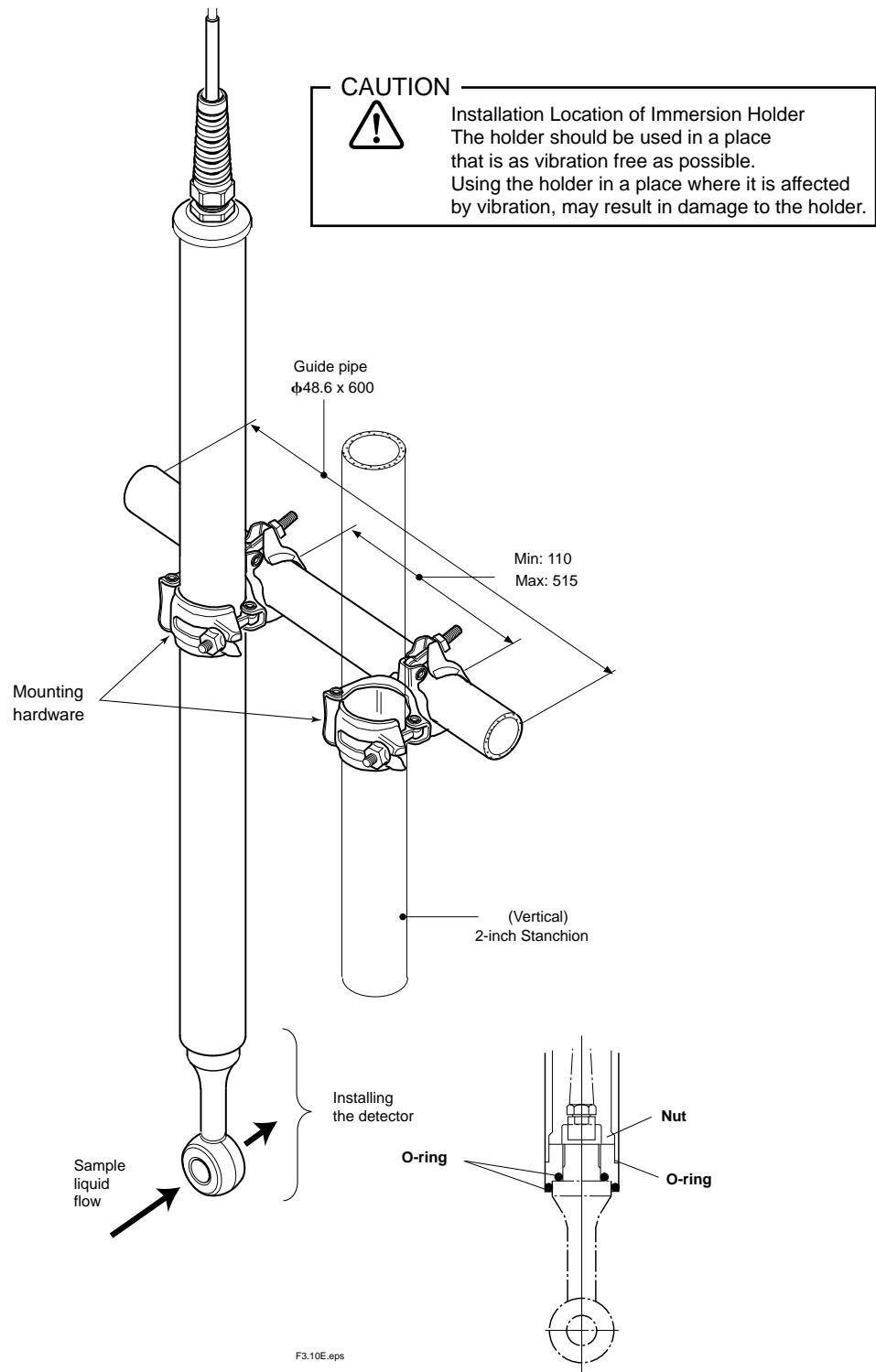

Figure 3.10 Method of Installing an Immersion Holder

## 3.2 Caution when install the sensor

### 3.2.1 Instructions for the mounting of the ISC40□J Inductive Conductivity Sensor in a fitting —Different mounting procedures depending on sealing method

Fittings - holders, subassemblies, flanges and adapters - for the ISC40□J Inductive Conductivity Sensor have different joint design depending on thus use different sealing methods: O-ring or gasket sealing. It is therefore necessary to identify the sealing method of fitting to be used before mounting the sensor in the fitting and take the appropriate procedure. The following pages describe the mounting procedures.

The inductive conductivity sensor comes with two O-rings (large and small) and a gasket. Use properly according to the procedure.

Item	Part Number	
	Standard	Optional *
O-ring (large, 40.64 mm ID)	K9414EF (Viton)	K9414EA (EPDM)
O-ring (small, 26.57 mm ID)	K9414EG (Viton)	K9414EB (EPDM)
Gasket	K9414DS (Viton)	K9414DA (EPDM)

\* When option code "/EP" is specified.

T3.2E.eps



#### SEE ALSO

- When the sensor is installed in the ISC40F□ fittings—previous version, refer to Appendix I.

Take the appropriate procedure referring to pages Table 3.1.

**Table 3.1**

A: O-ring installed		
Refer to	Mounting procedure	Model and code
p3-9	A1. Immersion holder (holder material: C-PVC, SUS316)	ISC40FDJ-V ISC40FDJ-S
p3-10	A2. Flow-through holders	ISC40FFJ-PJ, ISC40FFJ-PA ISC40FFJ-FJ, ISC40FFJ-FA ISC40FFJ-SJ, ISC40FFJ-SA
p3-11	A3. Direct insertion subassemblies	ISC40FSJ-SCWJ, ISC40FSJ-SCSJ ISC40FSJ-PCSJ, ISC40FSJ-FCSJ
p3-12	A4. Optional flanges	ISC40□J.../SFJ, /PFJ, /FFJ5, /SFD, /SFA
p3-13	A5. Optional screw-in adapters	ISC40□J.../SSG, /PSG, /FSJ
B: O-ring Not installed		
Refer to	Mounting procedure	Model and code
p3-14	B1. Direct insertion subassemblies (Coupling welded, Screw-in Socket)	ISC40FSJ-SCWJ, ISC40FSJ-SCSJ ISC40FSJ-PCSJ, ISC40FSJ-FCSJ

### 3.2.2 How to mount the sensor using an O-ring — When an O-ring is installed in a fitting —

#### A1. Immersion holders: ISC40FDJ-V (holder material: C-PVC) and ISC40FDJ-S (holder material: SUS316)

- 1) Unscrew the ferrule from the end of the immersion holder.
- 2) Remove the nut from the sensor, and install a small O-ring (supplied with the sensor) onto the sensor. Also, replace two O-rings installed in the removed ferrule with new ones. Do not use a large O-ring and a gasket supplied with the sensor.

NOTE 1: O-rings for the ferrule of the holder are not supplied with the sensor and need to be purchased separately for recommended replacement. Do not use a large O-ring supplied with the sensor due to the different inside diameter. The O-ring (41.00 mm ID) installed outside the ferrule is similar in size to a large O-ring (40.64 mm ID) supplied with the sensor, so take care not to mix up.

NOTE 2: A new holder comes with the same small O-ring as the one supplied with the sensor. Either can be used. Retain the unused small O-ring for future use.

- 3) Slide the ferrule on the sensor.
- 4) Reinstall the nut and tighten to approximately 40 N·m (4 kgf·m) torque to fix the ferrule on the sensor.
- 5) Mount the sensor in the immersion holder by screwing the ferrule, with the sensor attached, into the end of the holder.

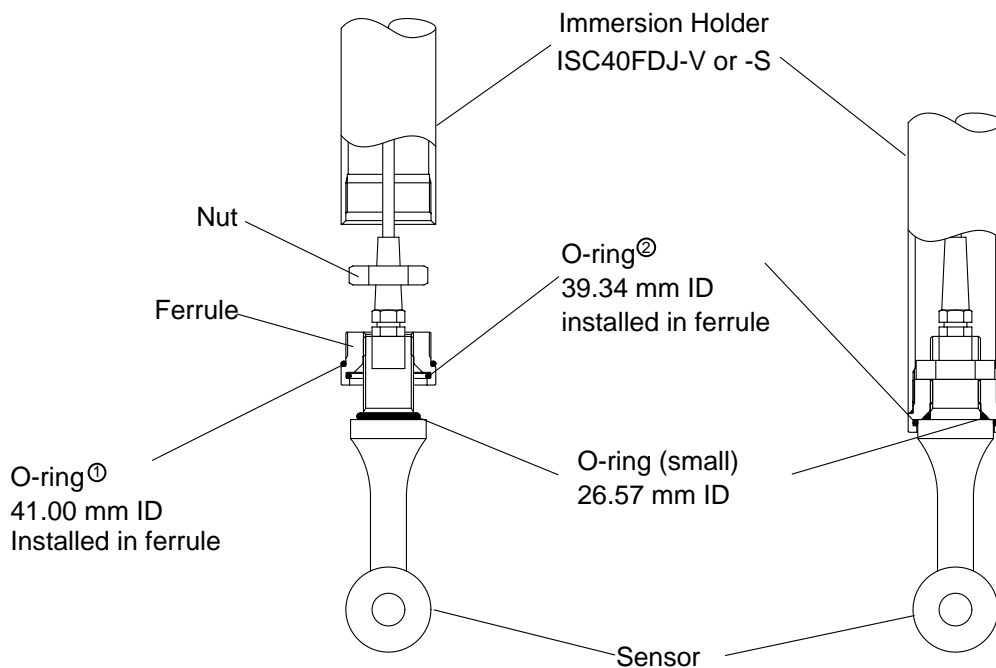

F3.11E.eps

① ② O-rings in ferrule are recommended to be replaced with new ones (separately purchased) when sensor is replaced.

Replacement Part	Part Number	
① O-ring, 41.00 mm ID	L9414DU (Viton)	K9414EJ (EPDM)*
② O-ring, 39.34 mm ID	K9414DT (Viton)	K9414EC (EPDM)*

\*When option code "/EP" has been specified upon purchase of holder.

Figure 3.11

**A2. Flow-through holders: ISC40FFJ-PJ, ISC40FFJ-PA, ISC40FFJ-FJ, ISC40FFJ-FA, ISC40FFJ-SJ and ISC40FFJ-SA**

- 1) Unscrew the cap nut and remove the ferrule from the flow chamber.
- 2) Remove the nut from the sensor, and install a small O-ring (supplied with the sensor) onto the sensor. Also, replace the O-ring installed in the removed ferrule with a new large O-ring (supplied with the sensor). Do not use a gasket supplied with the sensor.  
 NOTE: A new holder comes with two O-rings (large and small), the same as the ones supplied with the sensor. Either can be used. Retain the unused O-rings for future use.
- 3) Slide the ferrule on the sensor and fix by reinstalling the nut. Tighten the nut to approximately 40 N·m (4 kgf·m) torque.
- 4) Mount the sensor in the flow holder by installing the ferrule, with the sensor attached, in the flow chamber and then tightening the cap nut to fix.

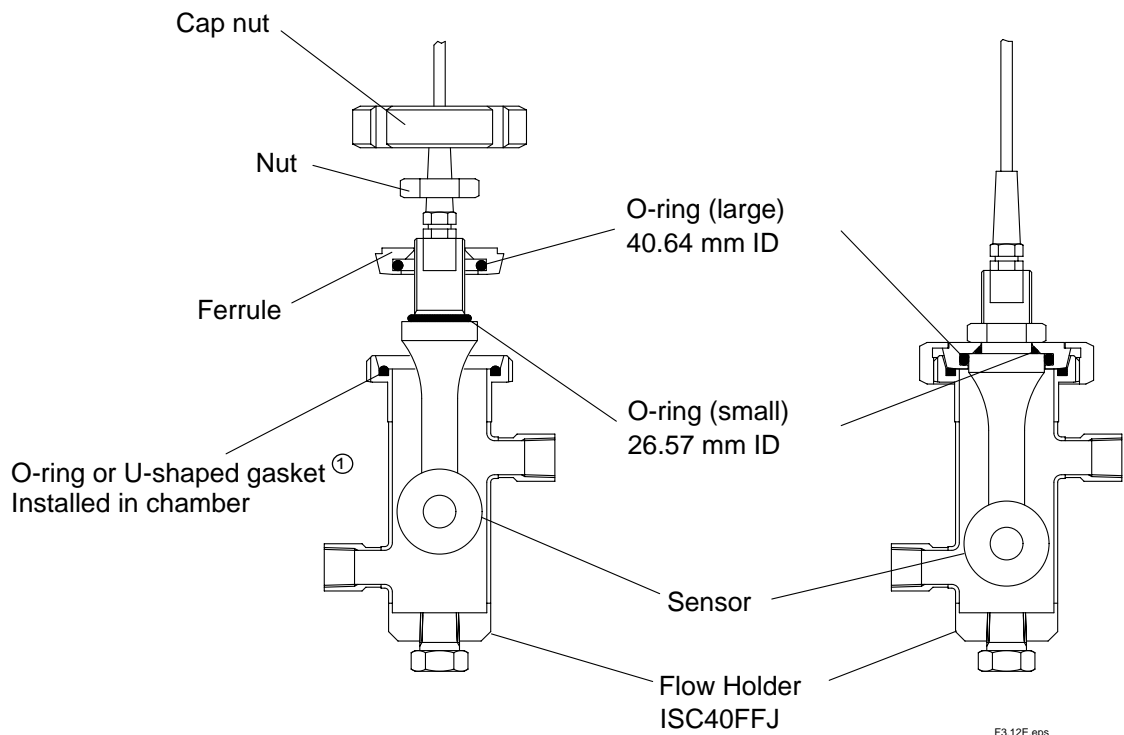

① O-ring or gasket in chamber is recommended to be replaced with new one (separately purchased) when sensor is replaced.

Replacement Part	Part Number	
PP/PVDF chamber: O-ring, 56.52 mm ID	K9414DP (Viton)	K9414DC (EPDM)*
SUS chamber: U-shaped gasket	K9414DV (Viton)	K9414DD (EPDM)*

\*When option code "/EP" has been specified upon purchase of holder.

NOTE: Above figure is of SUS flow chamber. In PP/PVDF flow chamber O-rings are installed in the same positions.

**Figure 3.12**

### A3. Direct insertion subassemblies: ISC40FSJ-SCWJ, ISC40FSJ-SCSJ, ISC40FFJ- PCSJ and ISC40FSJ- FCSJ

(The 3 inch clamp version, ISC40FSJ-STWJ, does not have O-ring sealing. Refer to Sec. 3.2.3-B1)

- 1) Unscrew the cap nut and remove the ferrule from the subassembly body.
- 2) Remove the nut from the sensor, and install a small O-ring (supplied with the sensor) onto the sensor. Also, replace the O-ring installed in the removed ferrule with a new large O-ring (supplied with the sensor). Do not use a gasket supplied with the sensor.

NOTE: A new subassembly comes with two O-rings (large and small), the same as the ones supplied with the sensor. Either can be used. Retain the unused O-rings for future use.

- 3) Slide the ferrule on the sensor and fix by reinstalling the nut. Tighten the nut to approximately 40 N·m (4 kgf·m) torque.
- 4) Mount the sensor in the subassembly by installing the ferrule, with the sensor attached, in the subassembly body and then tightening the cap nut to fix.

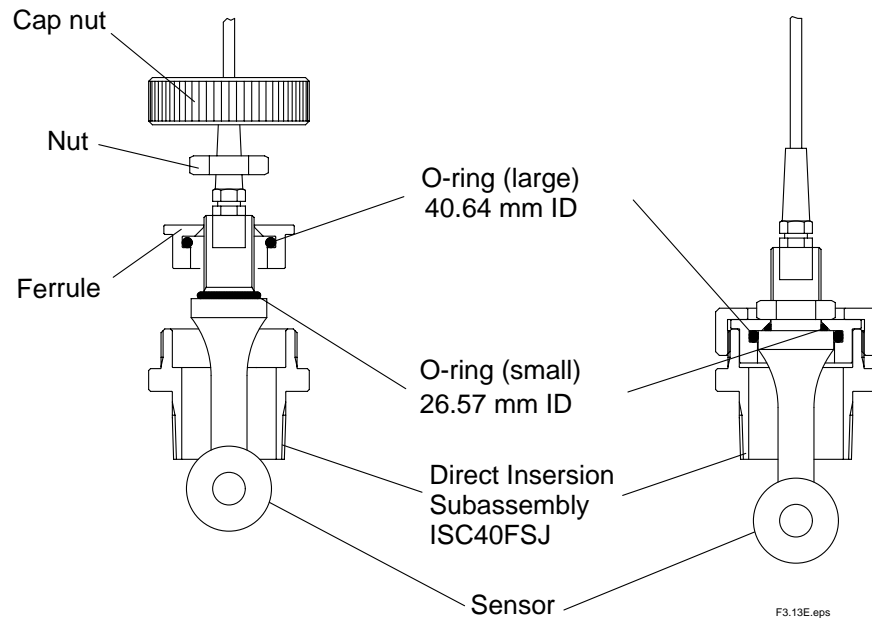

Figure 3.13

**A4. Optional flanges for the inductive conductivity sensor: Option Codes /SFJ, /PFJ, /FFJ5, /SFD, and /SFA**

- 1) Remove the nut from the sensor, and install a small O-ring (supplied with the sensor) onto the sensor. Also, replace the O-ring installed in the flange with a new large O-ring (supplied with the sensor). Do not use a gasket supplied with the sensor.

NOTE: A new flange comes with two O-rings (large and small), the same as the ones supplied with the sensor. Either can be used. Retain the unused O-rings for future use.

- 2) Slide the flange on the sensor and fix by reinstalling the nut. Tighten the nut to approximately 40 N·m (4 kgf·m) torque.

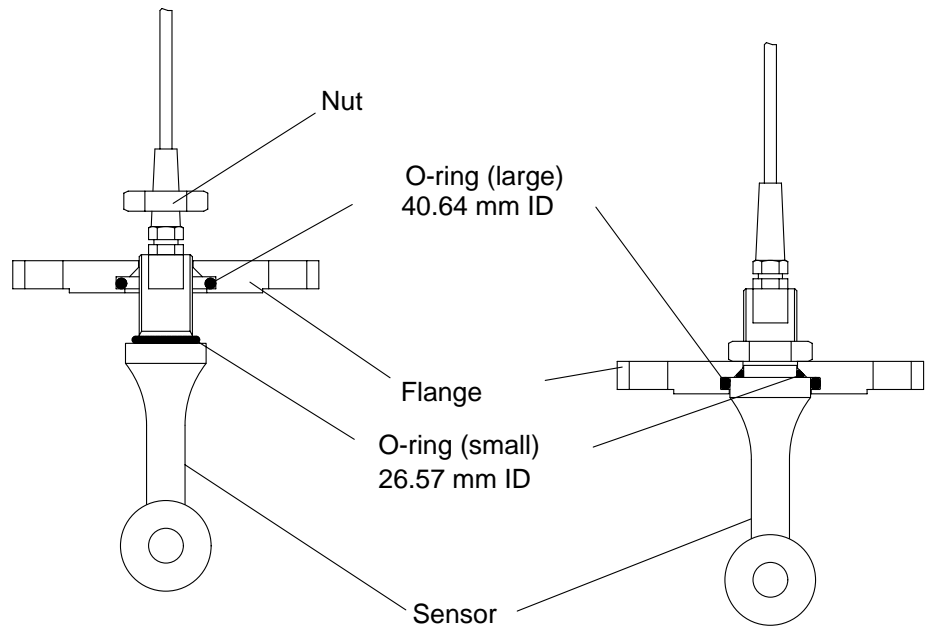

**Figure 3.14**

**A5. Optional screw-in adapters for the inductive conductivity sensor: Option Codes /SSG, /PSG, and /FSJ)**

- 1) Remove the nut from the sensor, and install a small O-ring (supplied with the sensor) onto the sensor. Also, replace the O-ring installed in the screw-in adapter with a new large O-ring (supplied with the sensor). Do not use a gasket supplied with the sensor.

NOTE: A new adapter comes with two O-rings (large and small), the same as the ones supplied with the sensor. Either can be used. Retain the unused O-rings for future use.

- 2) Slide the screw-in adapter on the sensor and fix by reinstalling the nut. Tighten the nut to approximately 40 N·m (4 kgf·m) torque.

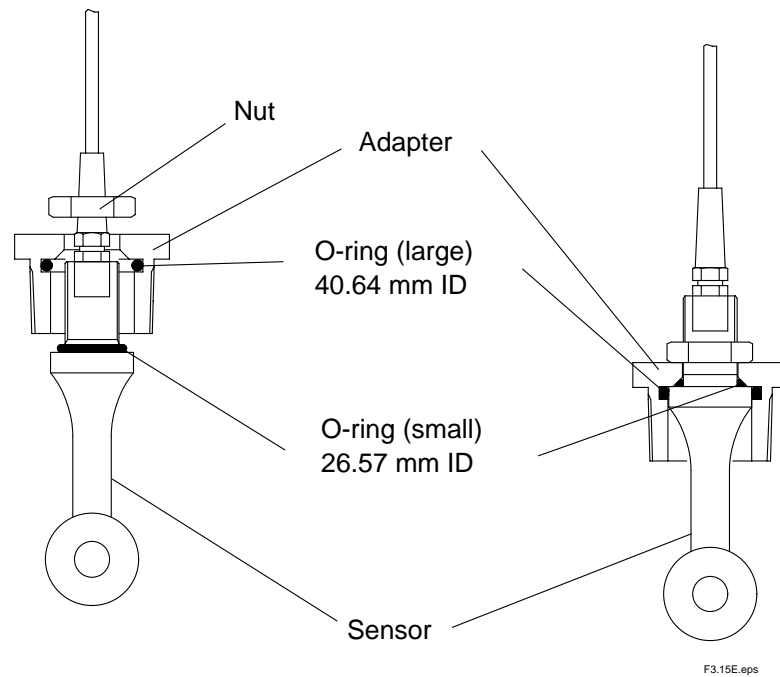
**Figure 3.15**

### 3.2.3 How to mount the sensor using a gasket — When an O-ring is not installed in a fitting —

#### B1. Direct insertion subassembly: ISC40FSJ-STWJ

- 1) Loosen the clamp and remove the cap from the subassembly body.
- 2) Remove the nut from the sensor. Replace the U-shaped gasket installed in the cap with a new one. Do not use a gasket and two O-rings (large and small) supplied with the sensor.

NOTE: A U-shaped gasket is not supplied with the sensor and need to be purchased separately for recommended replacement.

- 3) Slide the cap on the sensor and fix by reinstalling the nut. Tighten the nut to approximately 40 N·m (4 kgf·m) torque.
- 4) Mount the sensor in the subassembly by installing the cap, with the sensor attached, onto the subassembly body and then tightening the clamp to fix.

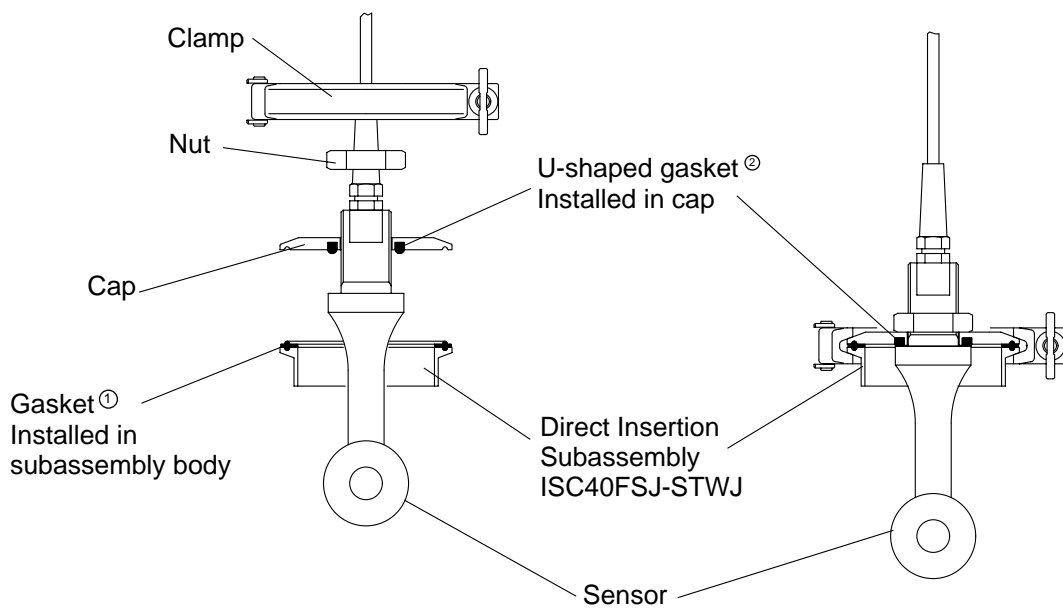

F3.16E.eps

- ①② Gaskets in subassembly and cap are recommended to be replaced with new ones (separately purchased) when sensor is replaced.

Replacement Part	Part Number	
① Gasket in subassy body	K9414BX (Silicone)	K9414DG (EPDM)*
② U-shaped gasket	K9414BY (Silicone)	K9414DE (EPDM)*

\*When option code "/EP" has been specified upon purchase of holder.

Figure 3.16

## 3.3 Wiring

### 3.3.1 General Cautions

The sensor cable transmits low voltage, high frequency signals and should be installed separately from any high voltage, high current and/or power switching cables. This to avoid any unintentional cross talk or other kind of interference of the conductivity measurement.

A sensor wiring diagram is shown in Figure 3.17.

Make sure that the numbering of sensor cable terminals agrees with the numbering of transmitter terminals they are connected to.

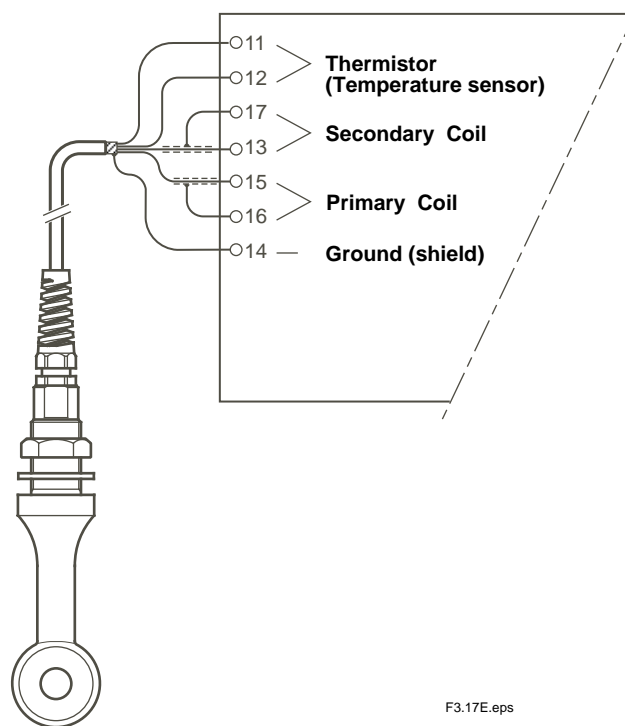
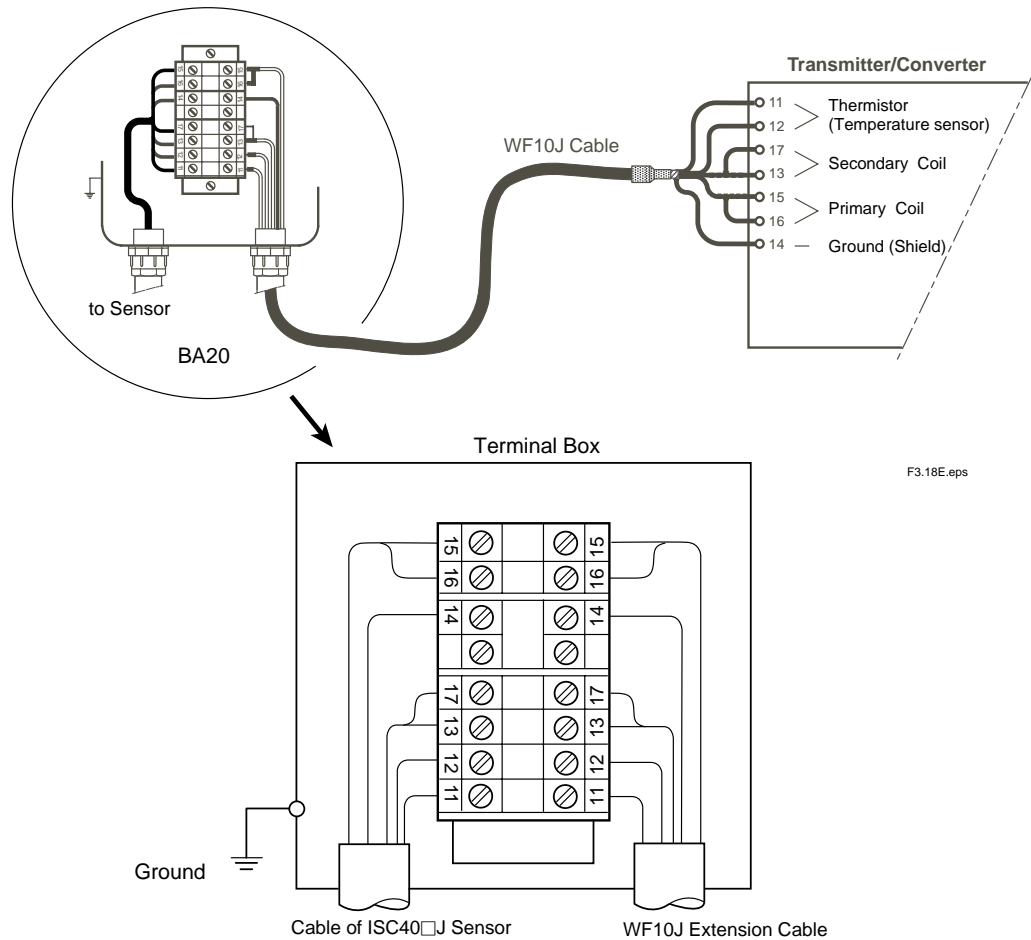

Figure 3.17

### 3.3.2 Connecting Sensor via Terminal Box (BA20) and Extension cable (WF10J)

When the standard cable lengths are not sufficient to connect sensor and transmitter/ converter, a terminal box and extension cable are used. Yokogawa's BA20 Terminal box and WF10J extension cable are high quality products, designed so as not to affect measurement accuracy. Total cable length should not exceed 50 m (sensor cable of 10 m, and extension cable of 40 m). BA20 and WF10J can not be used with ISC40SJ-TT sensor.



**Figure 3.18** Connecting WF10J extension cable to BA20 terminal box

# Appendix 1 Caution when install the detector in the ISC40F□ fittings

## A1.1 Instructions for the mounting of the ISC40□ Inductive Conductivity Detector in a fitting —Different mounting procedures depending on sealing method

Fittings - holders, subassemblies, flanges and adapters - for the ISC40□ Inductive Conductivity Detector have different joint design depending on the date of manufacture, and thus use different sealing methods: O-ring or gasket sealing. It is therefore necessary to identify the type and sealing method of fitting to be used before mounting the sensor in the fitting and take the appropriate procedure. The following pages describe the mounting procedures.

The inductive conductivity sensor comes with two O-rings (large and small) and a gasket. Use properly according to the procedure.

Item	Part Number	
	Standard	Optional *
O-ring (large, 40.64 mm ID)	K9414EF (Viton)	K9414EA (EPDM)
O-ring (small, 26.57 mm ID)	K9414EG (Viton)	K9414EB (EPDM)
Gasket	K9414DS (Viton)	K9414DA (EPDM)

\* When option code "/EP" is specified.

TA1.2E.eps

### How to identify the sealing method of a fitting

Visually check the inside of the joint part of the fitting to be used, to determine whether an O-ring is installed.

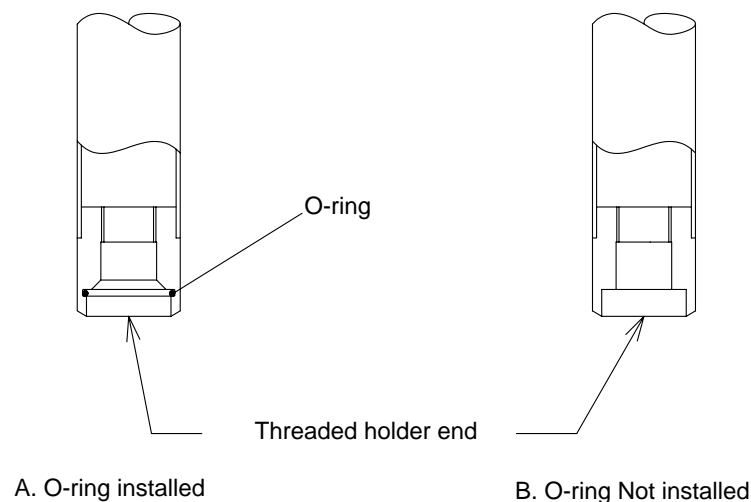

How to identify sealing method  
(Example: Immersion Holder ISC40FD-S)

FA1.1E.eps

**Figure A1.1**

**A. If an O-ring is installed in the joint of the fitting use an O-ring for sealing when mounting the sensor in the fitting.**

Take the appropriate procedure referring to Table A1.1.

**B. If an O-ring is not installed in the joint of the fitting, use a gasket for sealing when mounting the sensor in the fitting.**

Take the appropriate procedure referring to pages Table A1.1.

**Table A1.1**

A: O-ring installed		
Refer to	Mounting procedure	Model and code
p A1-3	A1. Immersion holder (holder material: C-PVC)	ISC40FD-V
p A1-4	A2. Immersion holder (holder material: SUS316)	ISC40FD-S
p A1-5	A3. Immersion holder [Style: S2] (holder material: C-PVC, SUS316)	ISC40FD-V [Style: S2] ISC40FD-S [Style: S2]
p A1-6	A4. Flow-through holders	ISC40FF-PJ, ISC40FF-PA ISC40FF-FJ, ISC40FF-FA ISC40FF-SJ, ISC40FF-SA
p A1-7	A5. Direct insertion subassemblies	ISC40FS-SCWJ, ISC40FS-SCSJ ISC40FS-PCSJ, ISC40FS-FCSJ
p A1-8	A6. Optional flanges	ISC40□.../SFJ, /PFJ, /FFJ5, /SFD, /SFA
p A1-9	A7. Optional screw-in adapters	ISC40□.../SSG, /PSG, /FSJ

B: O-ring Not installed		
Refer to	Mounting procedure	Model and code
p A1-10	B1. Immersion holder (holder material: C-PVC)	ISC40FD-V
p A1-11	B2. Immersion holder (holder material: SUS316)	ISC40FD-S
p A1-12	B3. Flow-through holders (holder material: PP, PVDF)	ISC40FF-PJ, ISC40FF-PA ISC40FF-FJ, ISC40FF-FA
p A1-13	B4. Flow-through holders (holder material: SUS316)	ISC40FF-SJ, ISC40FF-SA
p A1-14	B5. Direct insertion subassemblies (Coupling welded, Screw-in Socket)	ISC40FS-SCWJ, ISC40FS-SCSJ ISC40FS-PCSJ, ISC40FS-FCSJ
p A1-15	B6. Direct insertion subassemblies (IDF Clamp)	ISC40FS-STWJ
p A1-16	B7. Optional flanges	ISC40□.../SFJ, /PFJ, /FFJ5, /SFD, /SFA
p A1-16	B8. Optional screw-in adapters	ISC40□.../SSG, /PSG, /FSJ

## A1.2 How to mount the sensor using an O-ring — When an O-ring is installed in a fitting —

### A1. Immersion holder: the ISC40FD-V (holder material: C-PVC)

(For the Style S2 version of the ISC40FD-V, refer to Sec. A1.2-A3.)

- 1) Unscrew the ferrule from the end of the immersion holder.
- 2) Remove the nut from the sensor, and install a small O-ring (supplied with the sensor) onto the sensor. Also, replace two O-rings installed in the removed ferrule with new ones. Do not use a large O-ring and a gasket supplied with the sensor.

NOTE 1: O-rings for the ferrule of the holder are not supplied with the sensor and need to be purchased separately for recommended replacement. Do not use a large O-ring supplied with the sensor due to the different inside diameter.

NOTE 2: A new holder comes with the same small O-ring as the one supplied with the sensor. Either can be used. Retain the unused small O-ring for future use.

- 3) Screw the sensor into the ferrule and tighten to approximately 40 N·m (4 kgf·m) torque.
- 4) Reinstall the nut and tighten to approximately 40 N·m (4 kgf·m) torque to fix the ferrule on the sensor.
- 5) Mount the sensor in the immersion holder by screwing the ferrule, with the sensor attached, until it is snugly secured in the end of the holder.

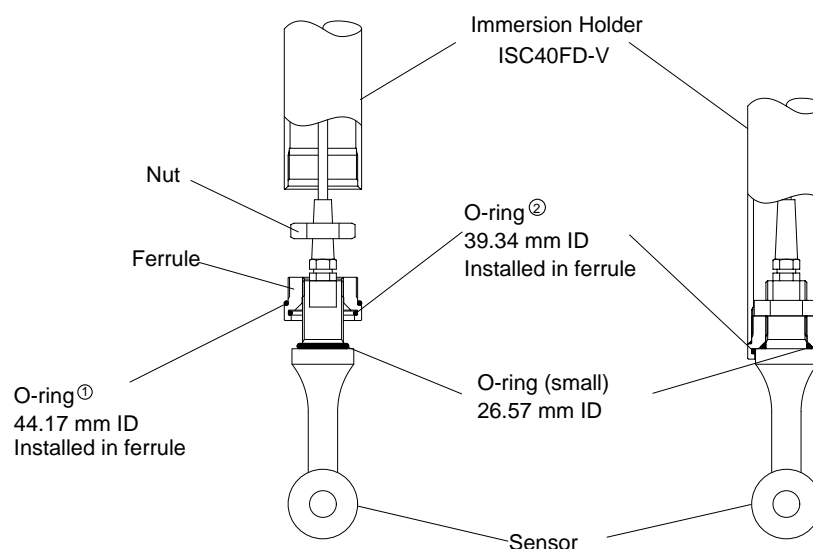

① ② O-rings in ferrule are recommended to be replaced with new ones (separately purchased) when sensor is replaced.

Replacement Part	Part Number	
① O-ring, 44.17 mm ID	L9817NC (Viton)	K9414DB (EPDM)*
② O-ring, 39.34 mm ID	K9414DT (Viton)	K9414EC (EPDM)*

\*When option code "/EP" has been specified upon purchase of holder.

Figure A1.2

**A2. Immersion holder: ISC40FD-S (holder material: SUS316)**

(For the Style S2 version of the ISC40FD-S, refer to Sec. A1.2-A3.)

- 1) Remove the nut from the sensor, and install a small O-ring (supplied with the sensor) onto the sensor. Also, replace the O-ring installed in the threaded end of the holder with a new one. Do not use a large O-ring and a gasket supplied with the sensor.

NOTE 1: An O-ring for the holder end is not supplied with the sensor and need to be purchased separately for recommended replacement. Do not use a large O-ring supplied with the sensor due to the different inside diameter.

NOTE 2: A new holder comes with the same small O-ring as the one supplied with the sensor. Either can be used. Retain the unused small O-ring for future use.

- 2) Mount the sensor in the holder by screwing the sensor into the threaded end of the holder. Tighten the sensor to approximately 40 N·m (4 kgf·m) torque. When tightening, do not hold the sensor with a bench clamp and take care not to damage the sensor.

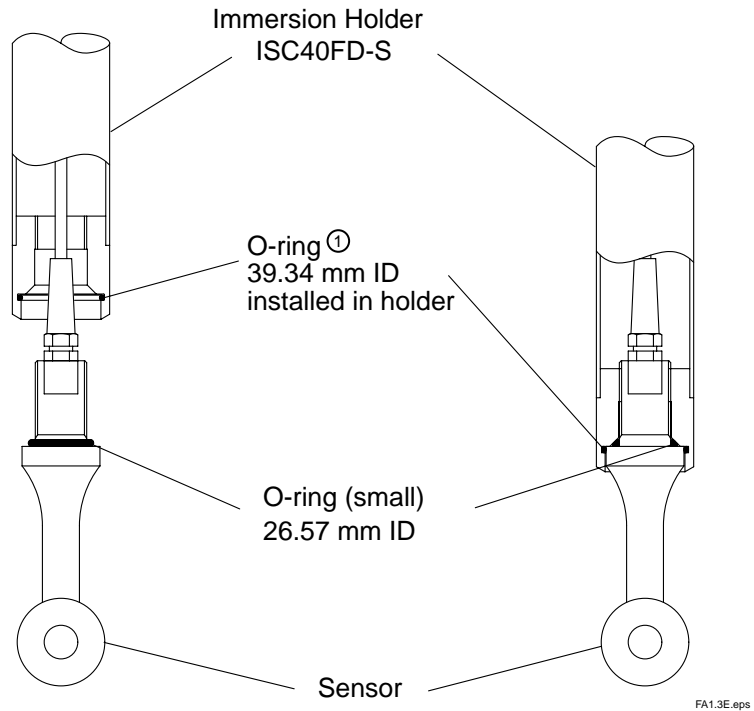

① O-ring in holder is recommended to be replaced with new one (separately purchased) when sensor is replaced.

Replacement Part	Part Number	
① O-ring, 39.34 mm ID	K9414DT (Viton)	K9414EC (EPDM)*

\*When option code "/EP" has been specified upon purchase of holder.

**Figure A1.3**

**A3. Immersion holders: Style S2 version of ISC40FD-V (holder material: C-PVC) and ISC40FD-S (holder material: SUS316)**

- 1) Unscrew the ferrule from the end of the immersion holder.
- 2) Remove the nut from the sensor, and install a small O-ring (supplied with the sensor) onto the sensor. Also, replace two O-rings installed in the removed ferrule with new ones. Do not use a large O-ring and a gasket supplied with the sensor.

NOTE 1: O-rings for the ferrule of the holder are not supplied with the sensor and need to be purchased separately for recommended replacement. Do not use a large O-ring supplied with the sensor due to the different inside diameter. The O-ring (41.00 mm ID) installed outside the ferrule is similar in size to a large O-ring (40.64 mm ID) supplied with the sensor, so take care not to mix up.

NOTE 2: A new holder comes with the same small O-ring as the one supplied with the sensor. Either can be used. Retain the unused small O-ring for future use.

- 3) Slide the ferrule on the sensor.
- 4) Reinstall the nut and tighten to approximately 40 N·m (4 kgf·m) torque to fix the ferrule on the sensor.
- 5) Mount the sensor in the immersion holder by screwing the ferrule, with the sensor attached, into the end of the holder.

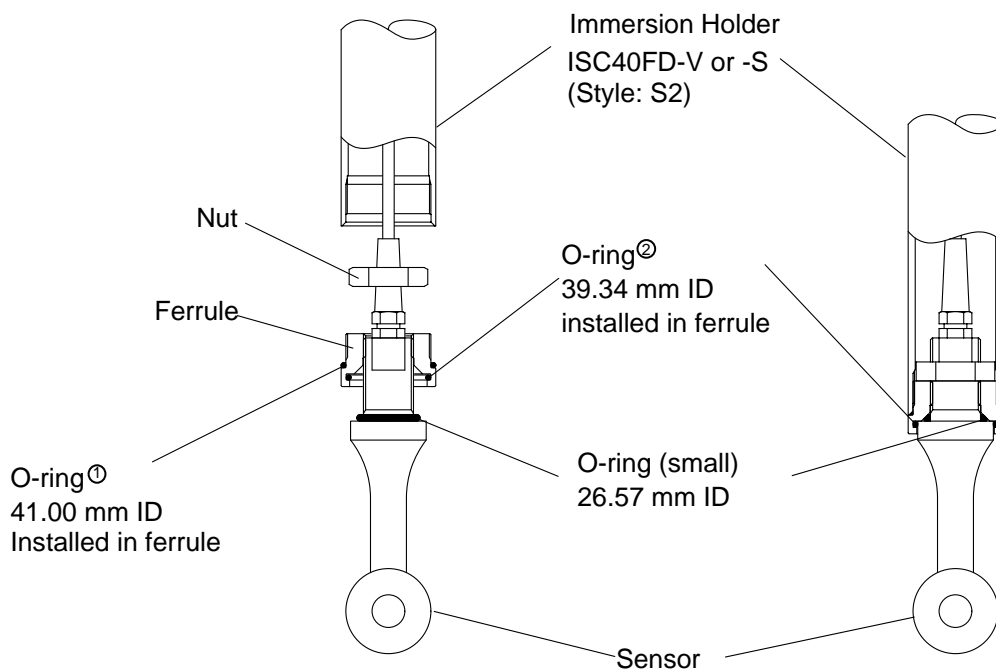

① ② O-rings in ferrule are recommended to be replaced with new ones (separately purchased) when sensor is replaced.

Replacement Part	Part Number	
① O-ring, 41.00 mm ID	L9414DU (Viton)	K9414EJ (EPDM)*
② O-ring, 39.34 mm ID	K9414DT (Viton)	K9414EC (EPDM)*

\*When option code "/EP" has been specified upon purchase of holder.

**Figure A1.4**

**A4. Flow-through holders: ISC40FF-PJ, ISC40FF-PA, ISC40FF-FJ, ISC40FF-FA, ISC40FF-SJ and ISC40FF-SA**

- 1) Unscrew the cap nut and remove the ferrule from the flow chamber.
- 2) Remove the nut from the sensor, and install a small O-ring (supplied with the sensor) onto the sensor. Also, replace the O-ring installed in the removed ferrule with a new large O-ring (supplied with the sensor). Do not use a gasket supplied with the sensor.  
 NOTE: A new holder comes with two O-rings (large and small), the same as the ones supplied with the sensor. Either can be used. Retain the unused O-rings for future use.
- 3) Slide the ferrule on the sensor and fix by reinstalling the nut. Tighten the nut to approximately 40 N·m (4 kgf·m) torque.
- 4) Mount the sensor in the flow holder by installing the ferrule, with the sensor attached, in the flow chamber and then tightening the cap nut to fix.

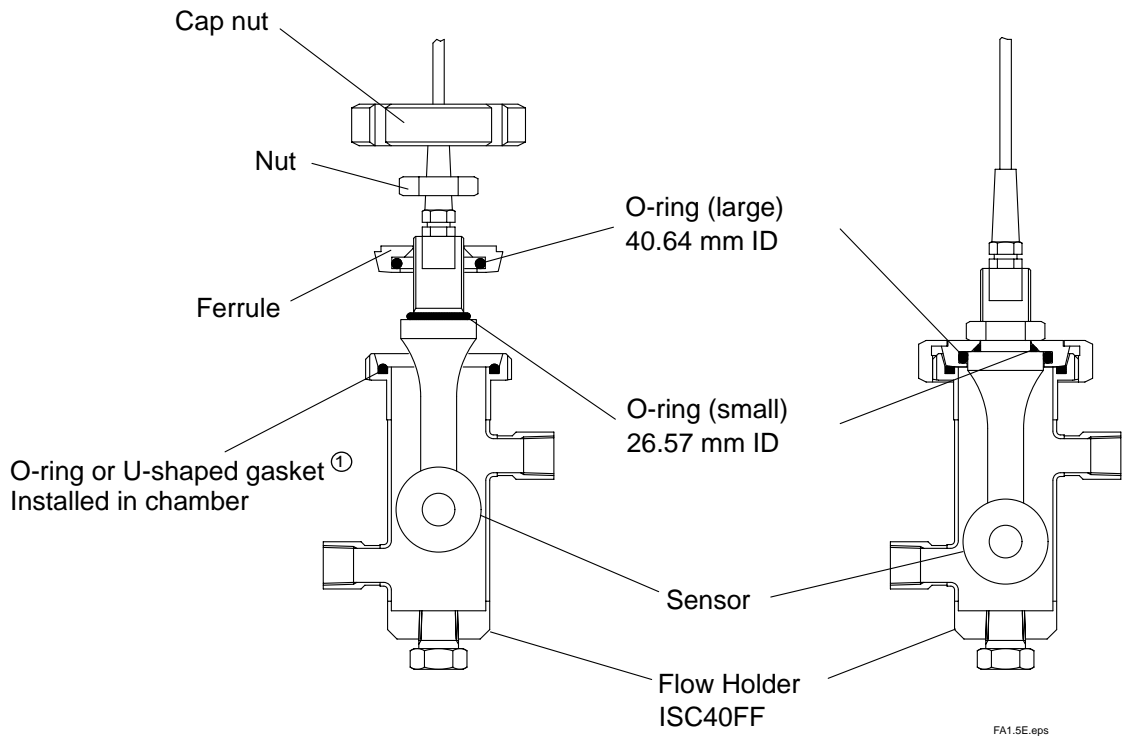

① O-ring or gasket in chamber is recommended to be replaced with new one (separately purchased) when sensor is replaced.

Replacement Part	Part Number	
PP/PVDF chamber: O-ring, 56.52 mm ID	K9414DP (Viton)	K9414DC (EPDM)*
SUS chamber: U-shaped gasket	K9414DV (Viton)	K9414DD (EPDM)*

\*When option code "/EP" has been specified upon purchase of holder.

NOTE: Above figure is of SUS flow chamber. In PP/PVDF flow chamber O-rings are installed in the same positions.

**Figure A1.5**

**A5. Direct insertion subassemblies: ISC40FS-SCWJ, ISC40FS-SCSJ, ISC40FF- PCSJ and ISC40FS- FCSJ**

(The 3" clamp version, ISC40FS-STWJ, does not have O-ring sealing. Refer to Sec. A1.3-B6)

- 1) Unscrew the cap nut and remove the ferrule from the subassembly body.
- 2) Remove the nut from the sensor, and install a small O-ring (supplied with the sensor) onto the sensor. Also, replace the O-ring installed in the removed ferrule with a new large O-ring (supplied with the sensor). Do not use a gasket supplied with the sensor.

NOTE: A new subassembly comes with two O-rings (large and small), the same as the ones supplied with the sensor. Either can be used. Retain the unused O-rings for future use.

- 3) Slide the ferrule on the sensor and fix by reinstalling the nut. Tighten the nut to approximately 40 N·m (4 kgf·m) torque.
- 4) Mount the sensor in the subassembly by installing the ferrule, with the sensor attached, in the subassembly body and then tightening the cap nut to fix.

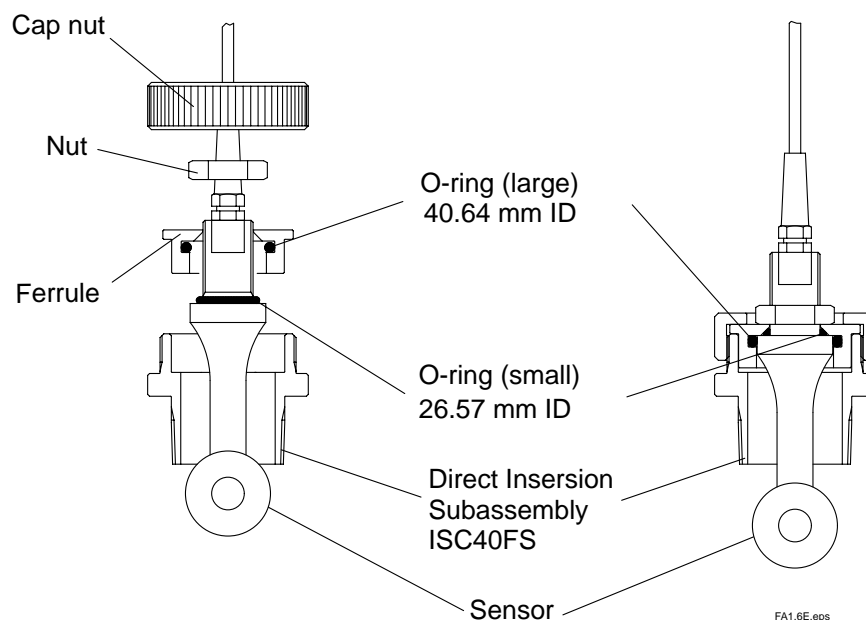

**Figure A1.6**

**A6. Optional flanges for the inductive conductivity sensor: Option Codes /SFJ, /PFJ, /FFJ5, /SFD, and /SFA**

- 1) Remove the nut from the sensor, and install a small O-ring (supplied with the sensor) onto the sensor. Also, replace the O-ring installed in the flange with a new large O-ring (supplied with the sensor). Do not use a gasket supplied with the sensor.

NOTE: A new flange comes with two O-rings (large and small), the same as the ones supplied with the sensor. Either can be used. Retain the unused O-rings for future use.

- 2) Slide the flange on the sensor and fix by reinstalling the nut. Tighten the nut to approximately 40 N·m (4 kgf·m) torque.

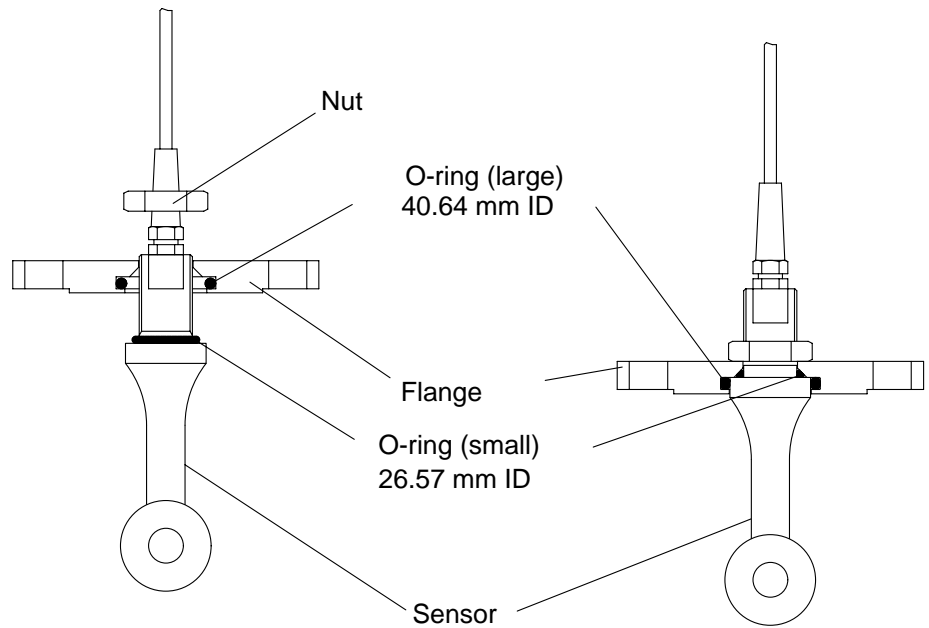

**Figure A1.7**

**A7. Optional screw-in adapters for the inductive conductivity sensor: Option Codes /SSG, /PSG, and /FSJ)**

- 1) Remove the nut from the sensor, and install a small O-ring (supplied with the sensor) onto the sensor. Also, replace the O-ring installed in the screw-in adapter with a new large O-ring (supplied with the sensor). Do not use a gasket supplied with the sensor.

NOTE: A new adapter comes with two O-rings (large and small), the same as the ones supplied with the sensor. Either can be used. Retain the unused O-rings for future use.

- 2) Slide the screw-in adapter on the sensor and fix by reinstalling the nut. Tighten the nut to approximately 40 N·m (4 kgf·m) torque.

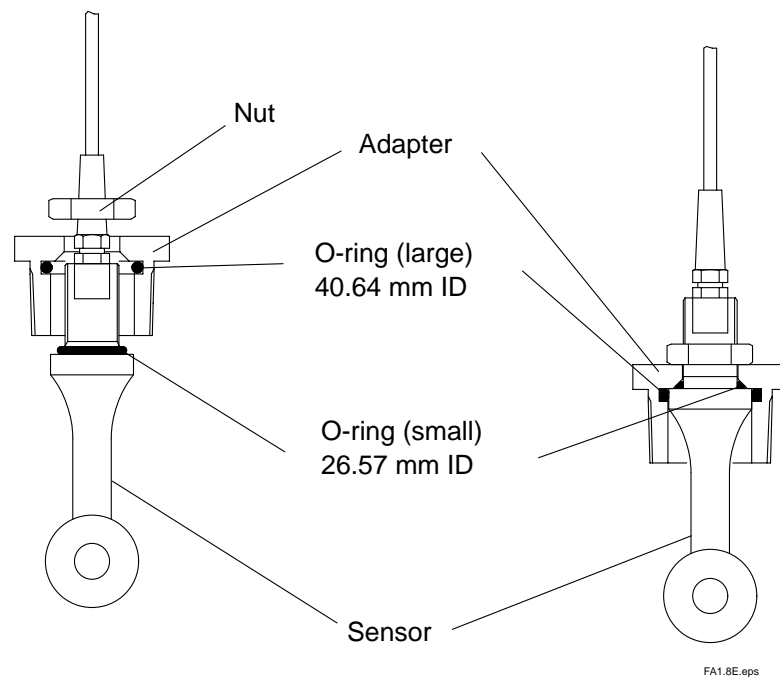
**Figure A1.8**

### A1.3 How to mount the sensor using a gasket — When an O-ring is not installed in a fitting —

#### B1. Immersion holder: ISC40FD-V (holder material: C-PVC)

- 1) Unscrew the ferrule from the end of the immersion holder.
- 2) Remove the nut from the sensor, and install a gasket (supplied with the sensor) onto the sensor. Do not use two O-rings (large and small) supplied with the sensor.
- 3) Screw the sensor into the ferrule and tighten to approximately 40 N·m (4 kgf·m) torque.
- 4) Reinstall the nut and tighten to approximately 40 N·m (4 kgf·m) torque to fix the ferrule on the sensor.
- 5) Mount the sensor in the immersion holder by screwing the ferrule, with the sensor attached, until it is snugly secured in the end of the holder.

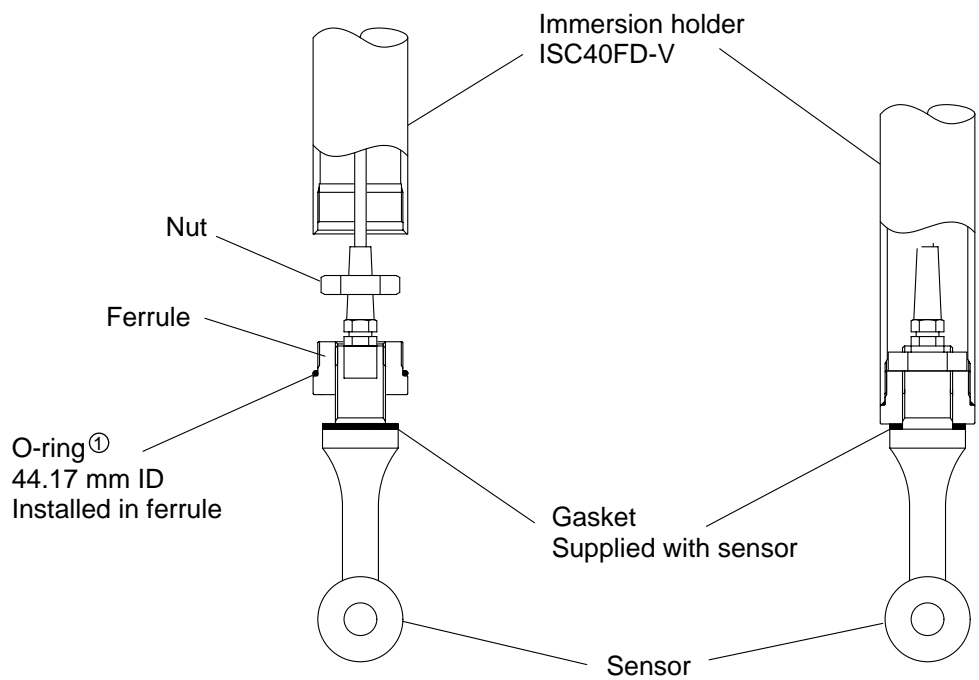

FA1.9E.eps

- ① O-ring in ferrule is recommended to be replaced with new one (separately purchased) when sensor is replaced.

Replacement Part	Part Number	
① O-ring, 44.17 mm ID	L9817NC (Viton)	K9414DB (EPDM)*

\*When option code "/EP" has been specified upon purchase of holder.

Figure A1.9

**B2. Immersion holder: ISC40FD-S (holder material: SUS316)**

- 1) Remove the nut from the sensor, and install a gasket (supplied with the sensor) onto the sensor. Do not use two O-rings (large and small) supplied with the sensor.
- 2) Mount the sensor in the holder by screwing the sensor into the threaded end of the holder. Tighten the sensor to approximately 40 N·m (4 kgf·m) torque. When tightening, do not hold the sensor with a bench clamp and take care not to damage the sensor.

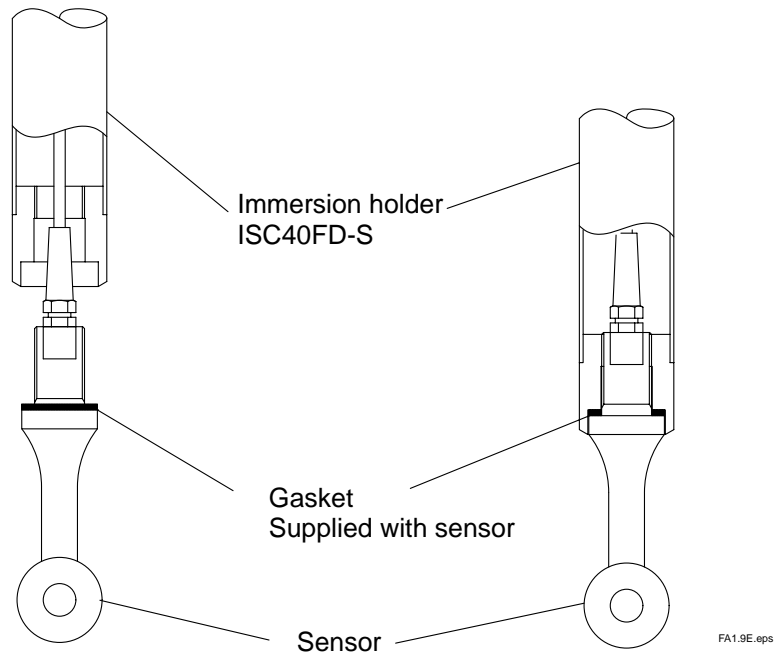
**Figure A1.10**

**B3. Flow-through holders: ISC40FF-PJ and ISC40FF-PA (holder material: PP), and ISC40FF-FJ and ISC40FF-FA (holder material: PVDF)**

- 1) Unscrew the cap nut and remove the ferrule from the flow chamber.
- 2) Remove the nut from the sensor, and install a gasket (supplied with the sensor) onto the sensor. Do not use two O-rings (large and small) supplied with the sensor.
- 3) Slide the ferrule on the sensor and fix by reinstalling the nut. Tighten the nut to approximately 40 N·m (4 kgf·m) torque.
- 4) Mount the sensor in the flow holder by installing the ferrule, with the sensor attached, in the flow chamber and then tightening the cap nut to fix.

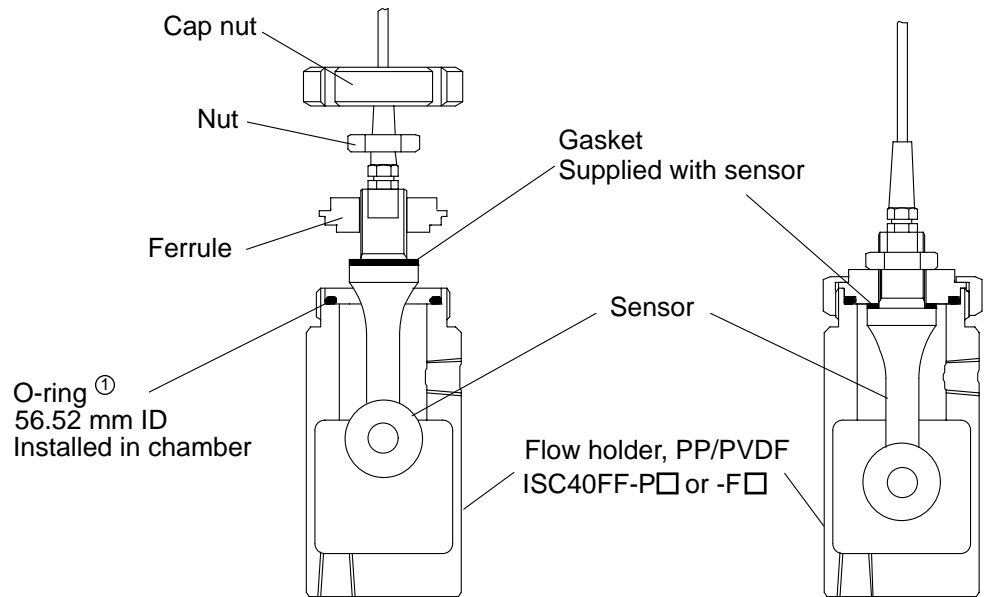

① O-ring in chamber is recommended to be replaced with new one (separately purchased) when sensor is replaced.

Replacement Part	Part Number	
① O-ring, 56.52 mm ID	K9414DP (Viton)	K9414DC (EPDM)*

\*When option code "/EP" has been specified upon purchase of holder.

**Figure A1.11**

**B4. Flow-through holders: ISC40FF-SJ and ISC40FF-SA (holder material: SUS316)**

- 1) Unscrew the cap nut and remove the ferrule from the flow chamber.
- 2) Remove the nut from the sensor, and replace the U-shaped gasket installed in the removed ferrule with a new one.

NOTE: A U-shaped gasket is not supplied with the sensor and need to be purchased separately for recommended replacement.

- 3) Slide the ferrule on the sensor and fix by reinstalling the nut. Tighten the nut to approximately 40 N·m (4 kgf·m) torque.
- 4) Mount the sensor in the flow holder by installing the ferrule, with the sensor attached, in the flow chamber and then tightening the cap nut to fix.

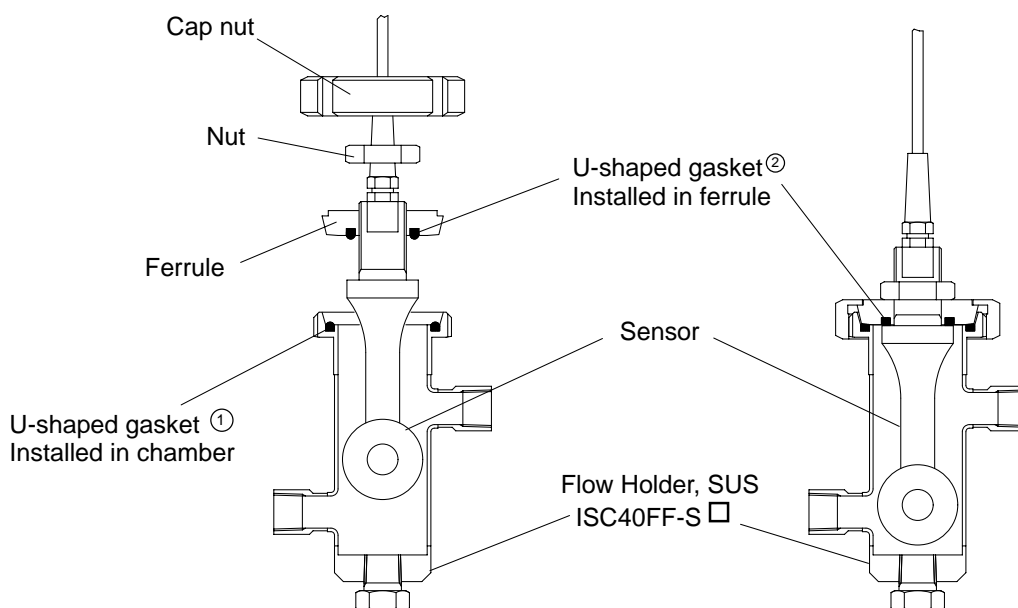

FA1.12E.eps

① ② Gaskets in chamber and ferrule are recommended to be replaced with new ones (separately purchased) when sensor is replaced.

Replacement Part	Part Number	
① Gasket in chamber	K9414DV (Viton)	K9414DD (EPDM)*
② Gasket in ferrule	K9414BY (Silicone)	K9414DE (EPDM)*

\*When option code "/EP" has been specified upon purchase of holder.

**Figure A1.12**

**B5. Direct insertion subassemblies: ISC40FS-SCWJ, ISC40FS-SCSJ, ISC40FS-PCSJ, and ISC40FS-FCSJ**

- 1) Unscrew the cap nut and remove the ferrule from the subassembly body.
- 2) Remove the nut from the sensor, and install a gasket (supplied with the sensor) onto the sensor. Do not use two O-rings (large and small) supplied with the sensor.
- 3) Slide the ferrule on the sensor and fix by reinstalling the nut. Tighten the nut to approximately 40 N·m (4 kgf·m) torque.
- 4) Mount the sensor in the subassembly by installing the ferrule, with the sensor attached, in the subassembly body and then tightening the cap nut to fix.

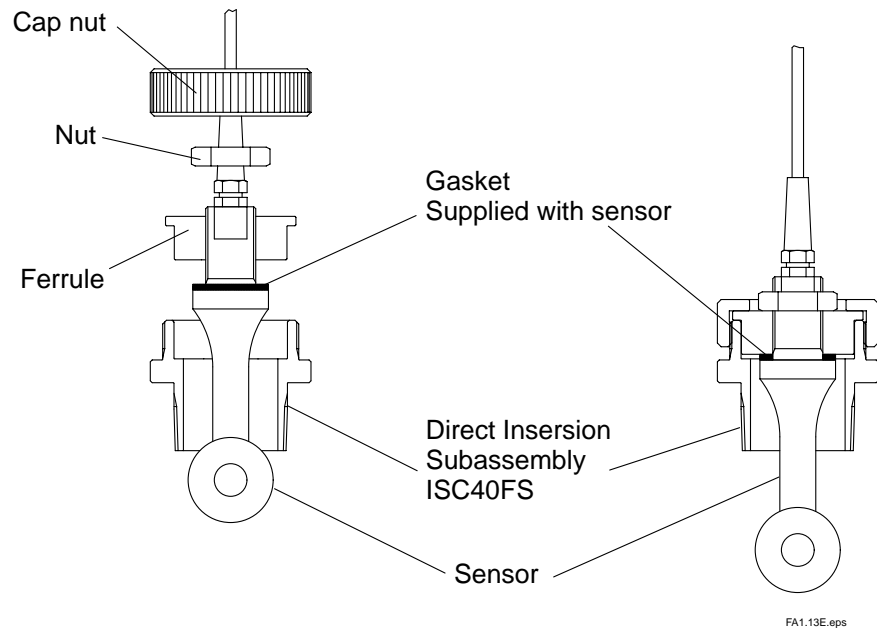

**Figure A1.13**

**B6. Direct insertion subassembly: ISC40FS-STWJ**

- 1) Loosen the clamp and remove the cap from the subassembly body.
- 2) Remove the nut from the sensor. Replace the U-shaped gasket installed in the cap with a new one. Do not use a gasket and two O-rings (large and small) supplied with the sensor.

NOTE: A U-shaped gasket is not supplied with the sensor and need to be purchased separately for recommended replacement.

- 3) Slide the cap on the sensor and fix by reinstalling the nut. Tighten the nut to approximately 40 N·m (4 kgf·m) torque.
- 4) Mount the sensor in the subassembly by installing the cap, with the sensor attached, onto the subassembly body and then tightening the clamp to fix.

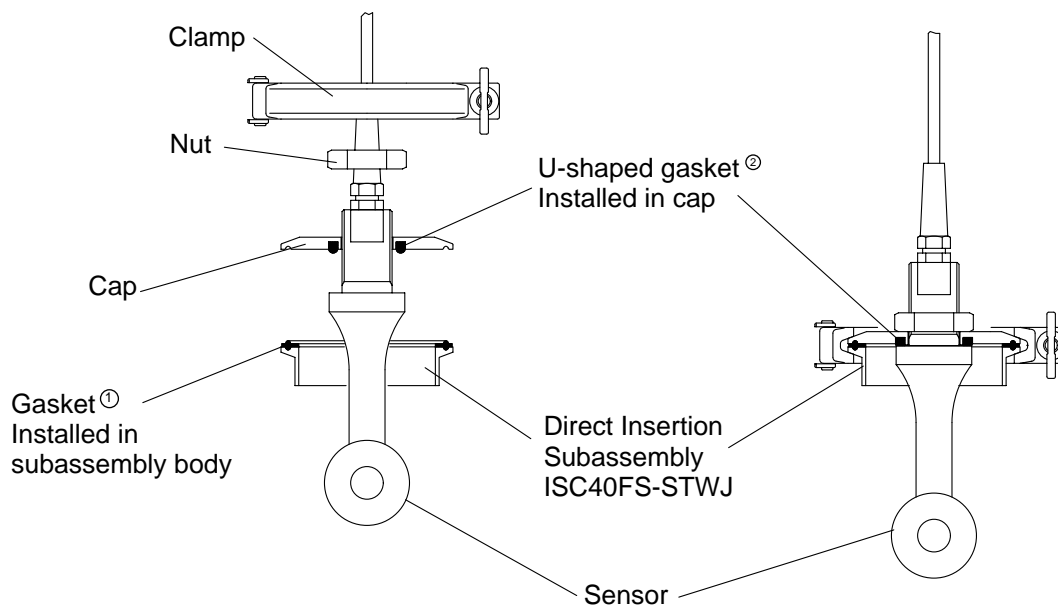

FA1.14E.eps

- ①② Gaskets in subassembly and cap are recommended to be replaced with new ones (separately purchased) when sensor is replaced.

Replacement Part	Part Number	
① Gasket in subassy body	K9414BX (Silicone)	K9414DG (EPDM)*
② U-shaped gasket	K9414BY (Silicone)	K9414DE (EPDM)*

\*When option code "/EP" has been specified upon purchase of holder.

**Figure A1.14**

**B7. Optional flanges for the inductive conductivity sensors: Option Codes /SFJ, /PFJ, /FFJ5, /SFD, and /SFA)**

- 1) Remove the nut from the sensor, and install a gasket (supplied with the sensor) onto the sensor. Do not use two O-rings (large and small) supplied with the sensor.
- 2) Slide the flange on the sensor and fix by reinstalling the nut. Tighten the nut to approximately 40 N·m (4 kgf·m) torque.

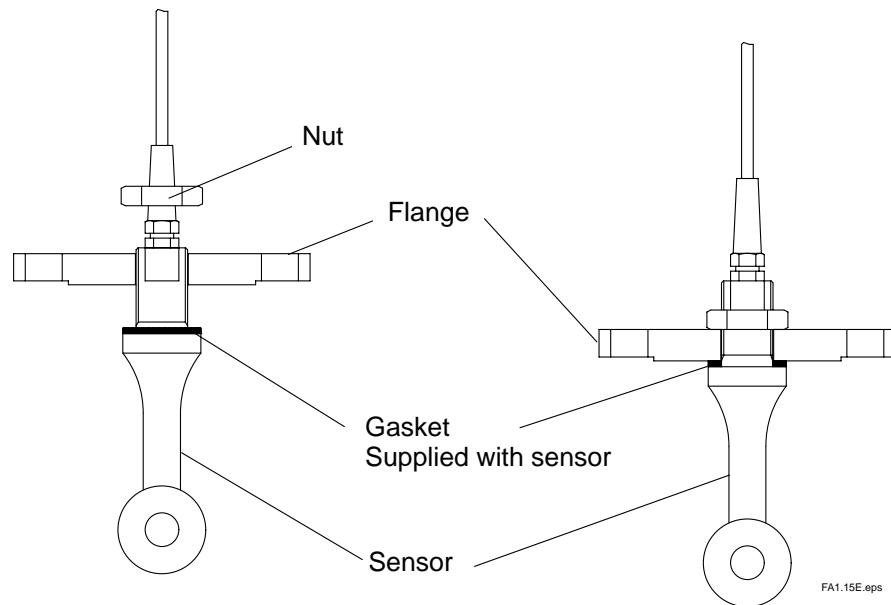

**Figure A1.15**

**B8. Optional screw-in adapters for the inductive conductivity sensors: Option Codes /SSG, /PSG, and /FSJ**

- 1) Remove the nut from the sensor, and install a gasket (supplied with the sensor) onto the sensor. Do not use two O-rings (large and small) supplied with the sensor.
- 2) Slide the screw-in adapter on the sensor and fix by reinstalling the nut. Tighten the nut to approximately 40 N·m (4 kgf·m) torque.

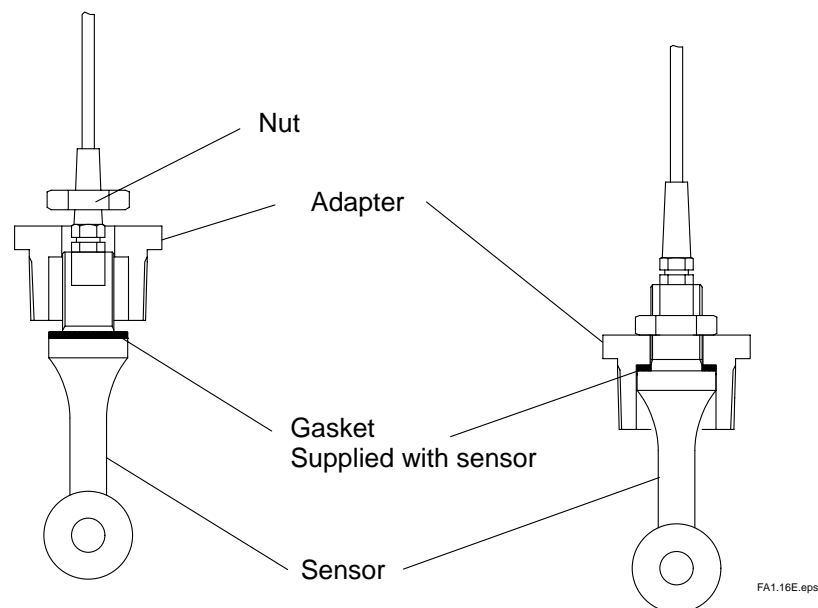

**Figure A1.16**

Note: Regarding the ISC40□, ISC40F□ delivered before 1998, see CMPL12D06A02-02EA 2nd Edition.  
Regarding the ISC40□, ISC40F□ Style S1 delivered after 1999, see CMPL12D06A02-02E 4th Edition.  
Regarding the ISC40□, ISC40F□ Style S2, see CMPL12D06A02-03E.

#### 1. Optional Flange of ISC40□J Detector

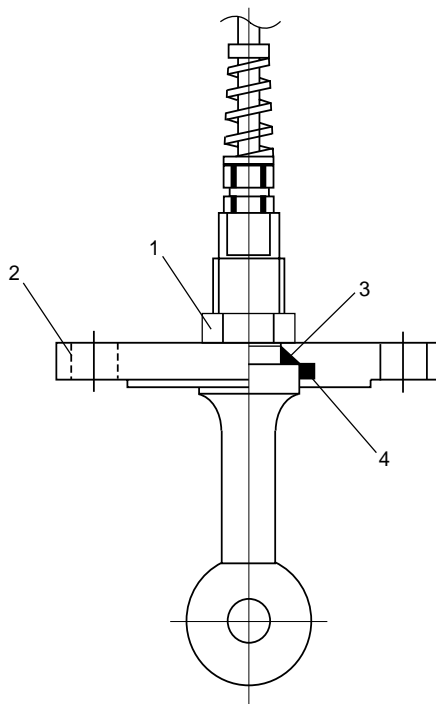

Item	Parts No.	Qty	Description
1	K9667BN	1	Nut
2	K9667ED	1	Flange DIN PN16 DN50 SUS316 (Option code: /SFD)
	K9667EE	1	Flange ANSI Class150 2 SUS316 (Option code: /SFA)
	K9667EA	1	Flange JIS 10K 50 RF SUS316 (Option code: /SFJ)
	K9667EB	1	Flange JIS 10K 50 FF PVC (Option code: /PFJ)
	K9667EC	1	Flange JIS 10K 50 FF PVDF (Option code: /FFJ5)
3	K9414EG	1	O-Ring (Viton, 1 pcs.)
	K9414EB	1	O-Ring (Ethylen propylene rubber, 1 pcs.) (Option code: /EP)
4	K9414EF	1	O-Ring (Viton, 1 pcs.)
	K9414EA	1	O-Ring (Ethylen propylene rubber, 1 pcs.) (Option code: /EP)

## 2. Optional Screw-in Adapter of ISC40□J Detector

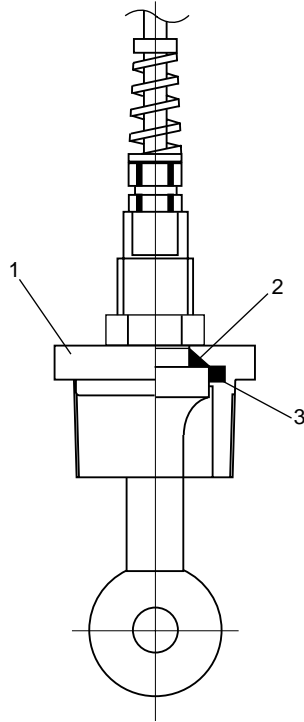

Item	Parts No.	Qty	Description
1	K9667EF	1	Screw-in Adapter SUS316 (Option code: /SSG)
	K9667EG	1	Screw-in Adapter PVC (Option code: /PSG)
	K9667EH	1	Screw-in Adapter PVDF (Option code: /FSJ)
2	K9414EG	1	O-Ring (Viton, 1 pcs.)
	K9414EB	1	O-Ring (Ethylen propylene rubber, 1 pcs.) (Option code: /EP)
3	K9414EF	1	O-Ring (Viton, 1 pcs.)
	K9414EA	1	O-Ring (Ethylen propylene rubber, 1 pcs.) (Option code: /EP)

### 3. Model ISC40FDJ Immersion Holder

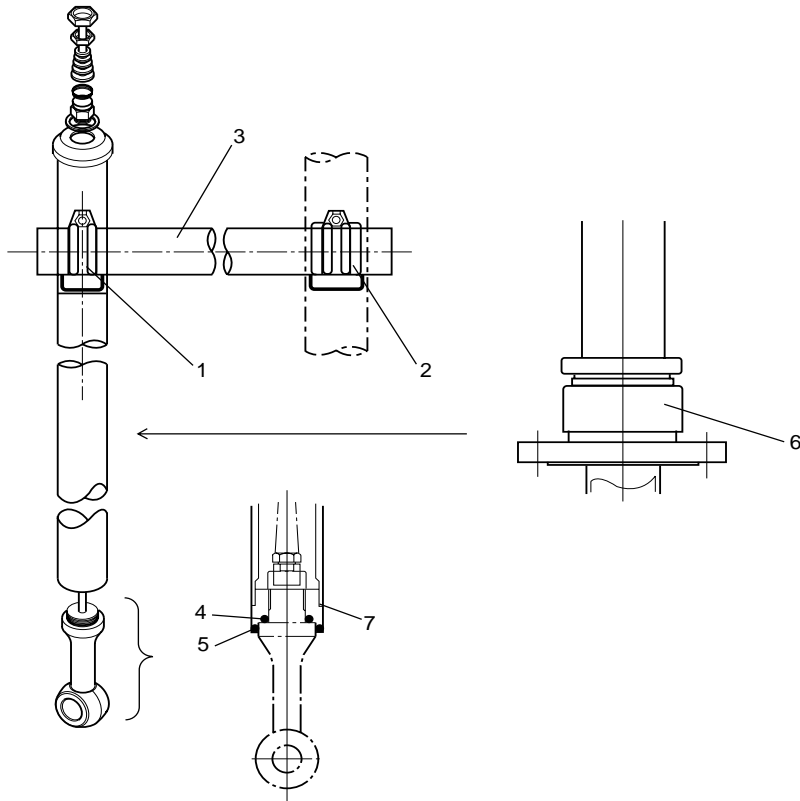

ISC40FDJ-S, -V

Item	Parts No.	Qty	Description
1	L9813VP	1	Clamp (Option code: /MS1)
	L9813VP	2	Clamp (Option code: /MS2)
2	L9813VN	1	Clamp (Option code: /MS1)
	L9813VN	2	Clamp (Option code: /MS2)
3	K9144AM	1	Pipe (Option code: /MS1)
4	K9144AM	2	Pipe (Option code: /MS2)
	K9414EG	1	O-Ring (Viton, 1 pcs.)
5	K9414EB	1	O-Ring (Ethylene propylene rubber, 1 pcs.) (Option code: /EP)
	K9414DT	1	O-Ring (Viton, 1 pcs.)
	K9414EC	1	O-Ring (Ethylene propylene rubber, 1 pcs.) (Option code: /EP)
6	K9667NS	1	Flange Assembly (Option code: /FA)
	K9667NX	1	Flange Assembly (Option code: /FA and /EP)
	K9667NY	1	Flange Assembly (Option code: /FBJ)
	K9667NZ	1	Flange Assembly (Option code: /FBJ and /EP)
7	K9414DU	1	O-Ring (Viton, 1 pcs.)
	K9414EJ	1	O-Ring (Ethylene propylene rubber, 1 pcs.) (Option code: /EP)

## 4. Model ISC40FFJ Flow-Through Holder

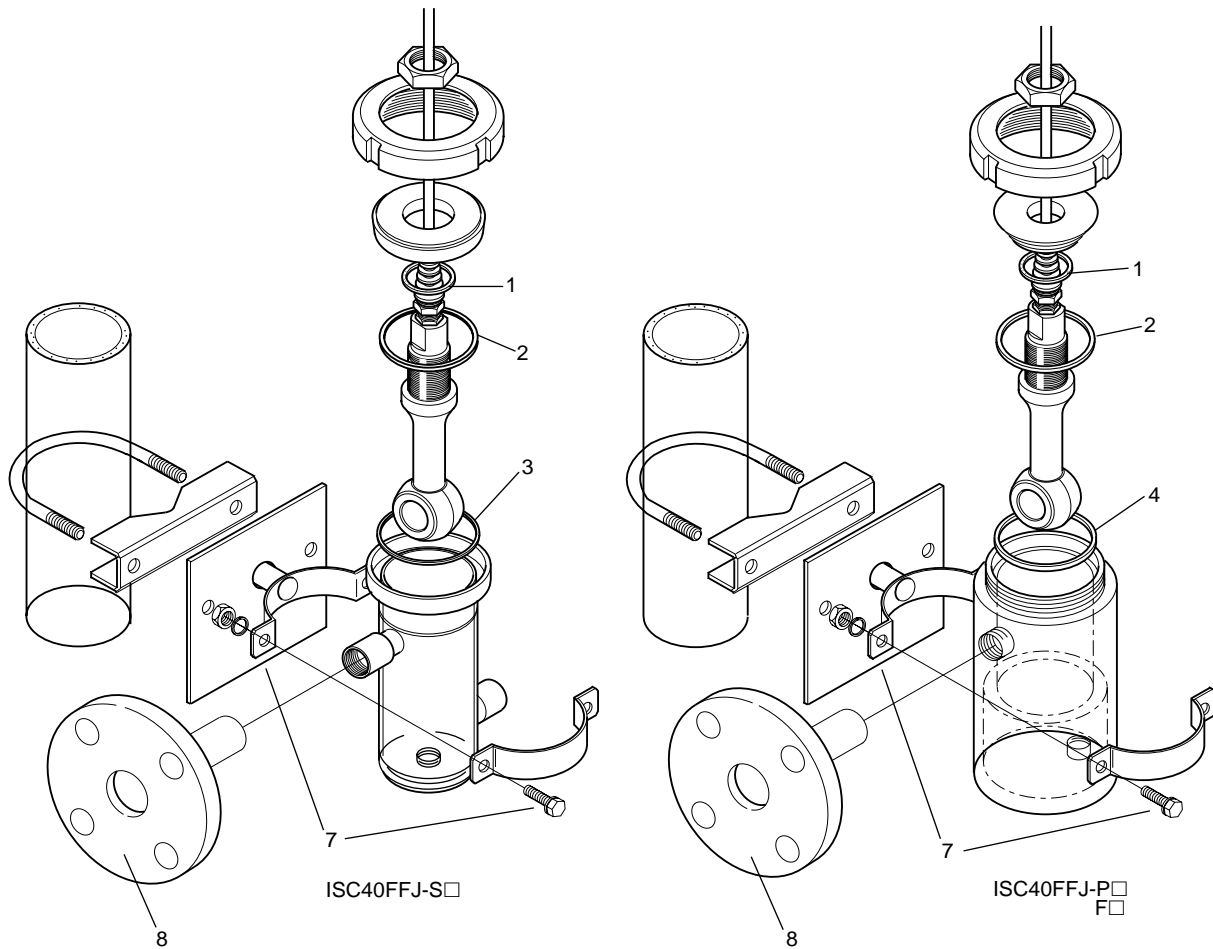

Item	Parts No.	Qty	Description
1	K9414EG	1	O-Ring (Viton,1 pcs.)
	K9414EB	1	O-Ring (Ethylene propylene rubber,1 pcs.) (Option code: /EP)
2	K9414EF	1	O-Ring (Viton,1 pcs.)
	K9414EA	1	O-Ring (Ethylene propylene rubber,1 pcs.) (Option code: /EP)
3	K9414DV	1	U-shaped Gasket (Viton,1 pcs.)
	K9414DD	1	U-shaped Gasket (EPDM) (Option code: /EP)
4	K9414DP	1	O-Ring (Viton,1 pcs.)
	K9414DC	1	O-Ring (EPDM) (Option code: /EP)
7	K9667SE	1	Clamp (Option code: /MS)
	K9667TF	1	Clamp (Option code: /MP)
8	K9667UN	1	Flange (Option code: /FSJ2)
	K9667UP	1	Flange (Option code: /FPJ2)
	K9667UQ	1	Flange (Option code: /FFJ2)
	K9667UA	1	Flange (Option code: /FS2)
	K9667UB	1	Flange (Option code: /FP2)
	K9667UC	1	Flange (Option code: /FF2)

## 5. Model ISC40FSJ Direct Insertion Adapter

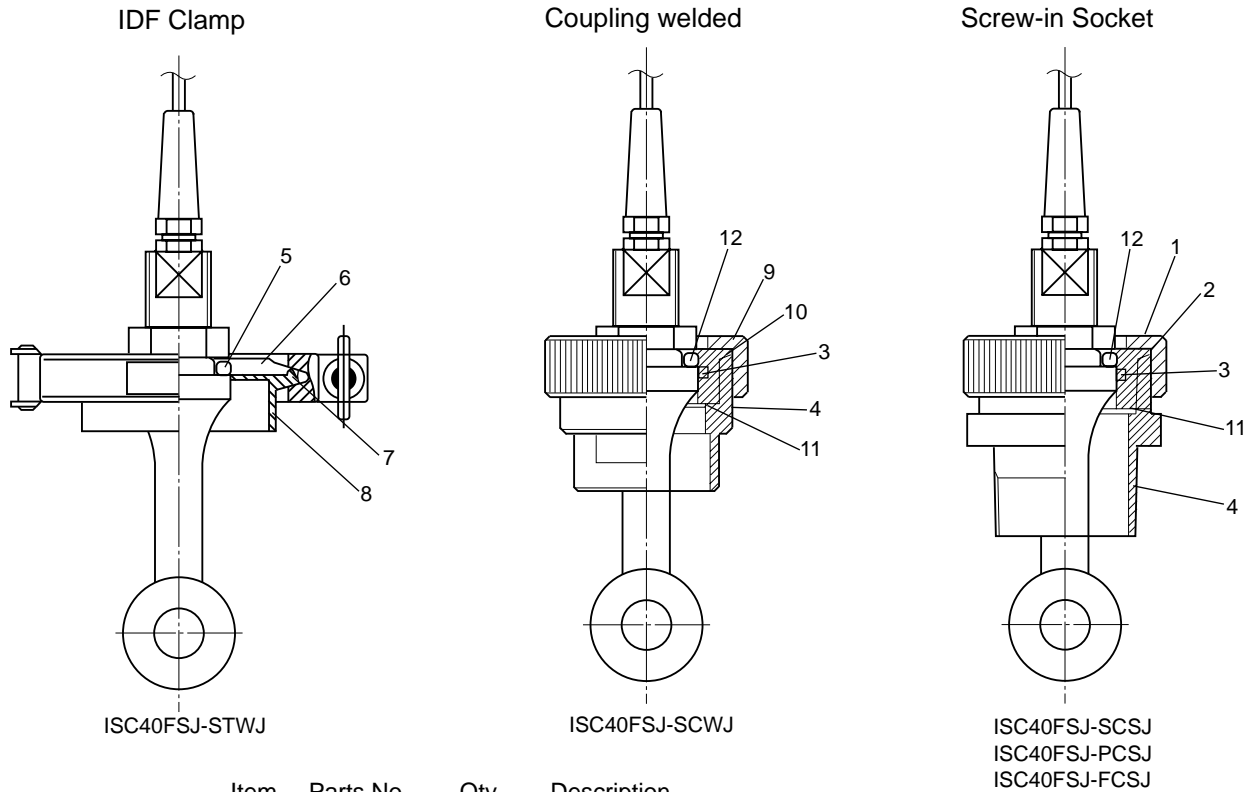

Item	Parts No.	Qty	Description
1	K9414CJ	1	Nut (SUS304)
2	K9414CK	1	Spacer (SUS316)
	K9414CN	1	Spacer (PVC)
	K9414CP	1	Spacer (PVDF)
3	K9414EF	1	O-Ring (Viton, 1 pcs.)
	K9414EA	1	O-Ring (Ethylene propylene rubber, 1 pcs.) (Option code: /EP)
4	K9414CM	1	Socket (SUS316) (Suffix code: -SCSJ)
	K9414CQ	1	Socket (PVC) (Suffix code: -PCSJ)
	K9414CR	1	Socket (PVDF) (Suffix code: -FCSJ)
	K9414CL	1	Socket (SUS316) (Suffix code: -SCWJ)
5	K9414BY	1	U-shaped Gasket (Silicon rubber)
	K9414DE	1	U-shaped Gasket (EPDM) (Option code: /EP)
6	K9414BT	1	Cap
7	K9414BX	1	Gasket (Silicon rubber)
	K9414DG	1	Gasket (EPDM) (Option code: /EP)
8	K9414BV	1	FERRULE (SUS316L)
9	K9414CJ	1	Nut (SUS304)
10	K9414CK	1	Spacer (SUS316)
11	Y9207XB	1	O-Ring (Viton, 1 pcs.)
	K9414DF	1	O-Ring (Ethylene propylene rubber, 1 pcs.) (Option code: /EP)
12	K9414EG	1	O-Ring (Viton, 1 pcs.)
	K9414EB	1	O-Ring (Ethylene propylene rubber, 1 pcs.) (Option code: /EP)

Note: Regarding the ISC40□, ISC40F□ delivered before 1998, see CMPL12D06A02-02EA 2nd Edition.  
 Regarding the ISC40□, ISC40F□ Style S1 delivered after 1999, see CMPL12D06A02-02E 4th Edition.  
 Regarding the ISC40□J, ISC40F□J, see CMPL12D06B02-01E.

#### 1. Optional Flange of ISC40□ Detector

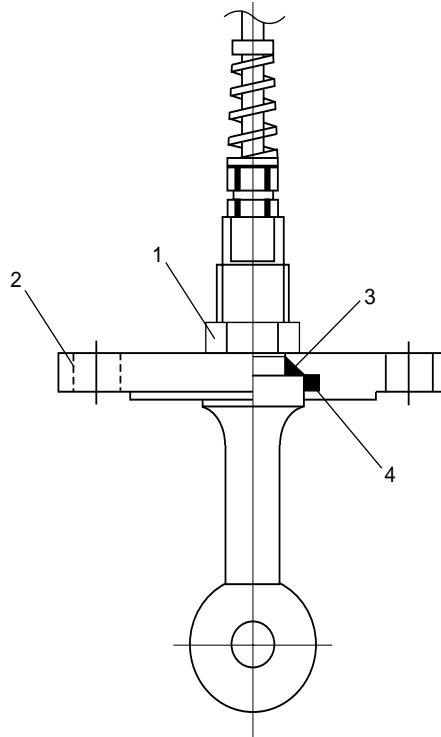

Item	Parts No.	Qty	Description
1	K9667BN	1	Nut
2	K9667ED	1	Flange DIN PN16 DN50 SUS316 (Option code: /SFD)
	K9667EE	1	Flange ANSI Class150 2 SUS316 (Option code: /SFA)
	K9667EA	1	Flange JIS 10K 50 RF SUS316 (Option code: /SFJ)
	K9667EB	1	Flange JIS 10K 50 FF PVC (Option code: /PFJ)
	K9667EC	1	Flange JIS 10K 50 FF PVDF (Option code: /FFJ5)
3	K9414EG	1	O-Ring (Viton, 1 pcs.)
	K9414EB	1	O-Ring (Ethylen propylene rubber, 1 pcs.) (Option code: /EP)
4	K9414EF	1	O-Ring (Viton, 1 pcs.)
	K9414EA	1	O-Ring (Ethylen propylene rubber, 1 pcs.) (Option code: /EP)

## 2. Optional Screw-in Adapter of ISC40□ Detector

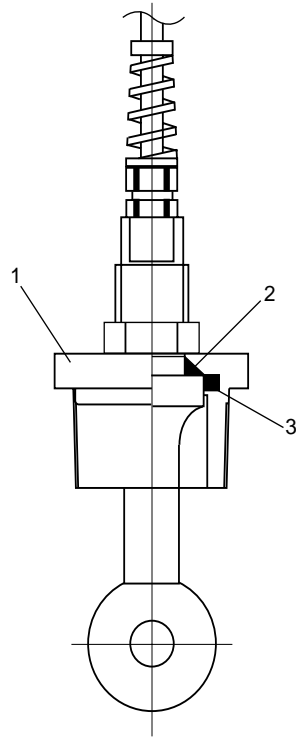

Item	Parts No.	Qty	Description
1	K9667EF	1	Screw-in Adapter SUS316 (Option code: /SSG)
	K9667EG	1	Screw-in Adapter PVC (Option code: /PSG)
	K9667EH	1	Screw-in Adapter PVDF (Option code: /FSJ)
2	K9414EG	1	O-Ring (Viton, 1 pcs.)
	K9414EB	1	O-Ring (Ethylen propylene rubber, 1 pcs.) (Option code: /EP)
3	K9414EF	1	O-Ring (Viton, 1 pcs.)
	K9414EA	1	O-Ring (Ethylen propylene rubber, 1 pcs.) (Option code: /EP)

### 3. Model ISC40FD Immersion Holder

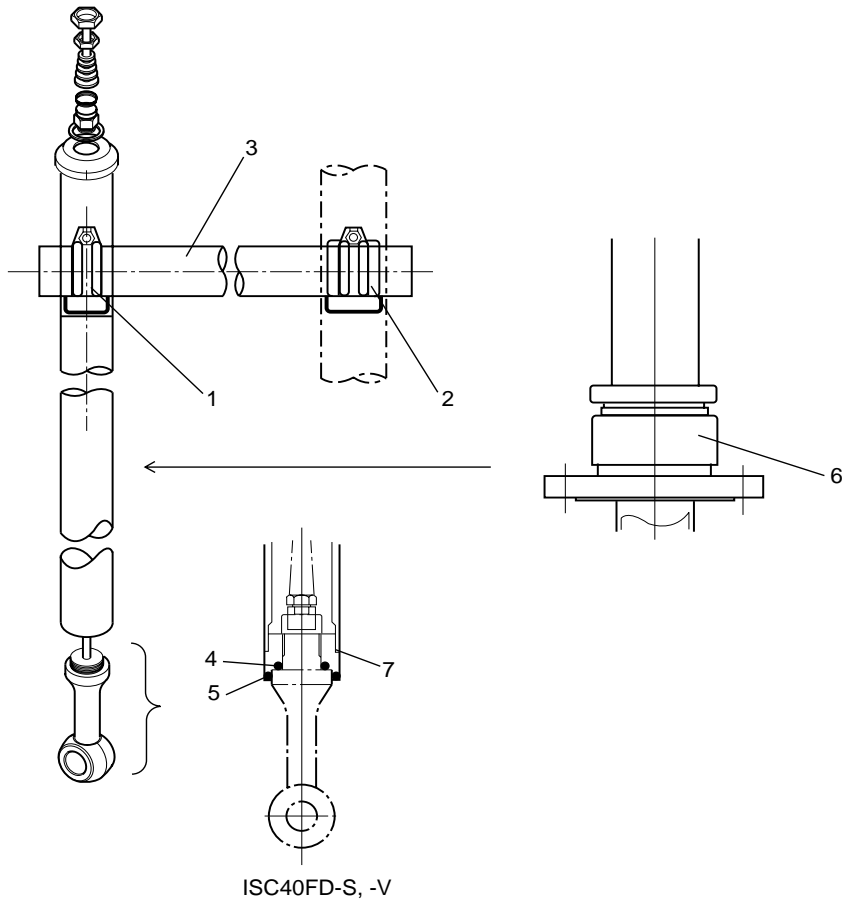

<u>Item</u>	<u>Parts No.</u>	<u>Qty</u>	<u>Description</u>
1	L9813VP	1	Clamp (Option code: /MS1)
	L9813VP	2	Clamp (Option code: /MS2)
2	L9813VN	1	Clamp (Option code: /MS1)
	L9813VN	2	Clamp (Option code: /MS2)
3	K9144AM	1	Pipe (Option code: /MS1)
	K9144AM	2	Pipe (Option code: /MS2)
4	K9414EG	1	O-Ring (Viton, 1 pcs.)
	K9414EB	1	O-Ring (Ethylene propylene rubber, 1 pcs.) (Option code: /EP)
5	K9414DT	1	O-Ring (Viton, 1 pcs.)
	K9414EC	1	O-Ring (Ethylene propylene rubber, 1 pcs.) (Option code: /EP)
6	K9667NS	1	Flange Assembly (Option code: /FBJ or /FA)
	K9667NX	1	Flange Assembly (Option code: /FBJ and /EP, or /FA and /EP)
7	K9414DU	1	O-Ring (Viton, 1 pcs.)
	K9414EJ	1	O-Ring (Ethylene propylene rubber, 1 pcs.) (Option code: /EP)

## 4. Model ISC40FF Flow-Through Holder

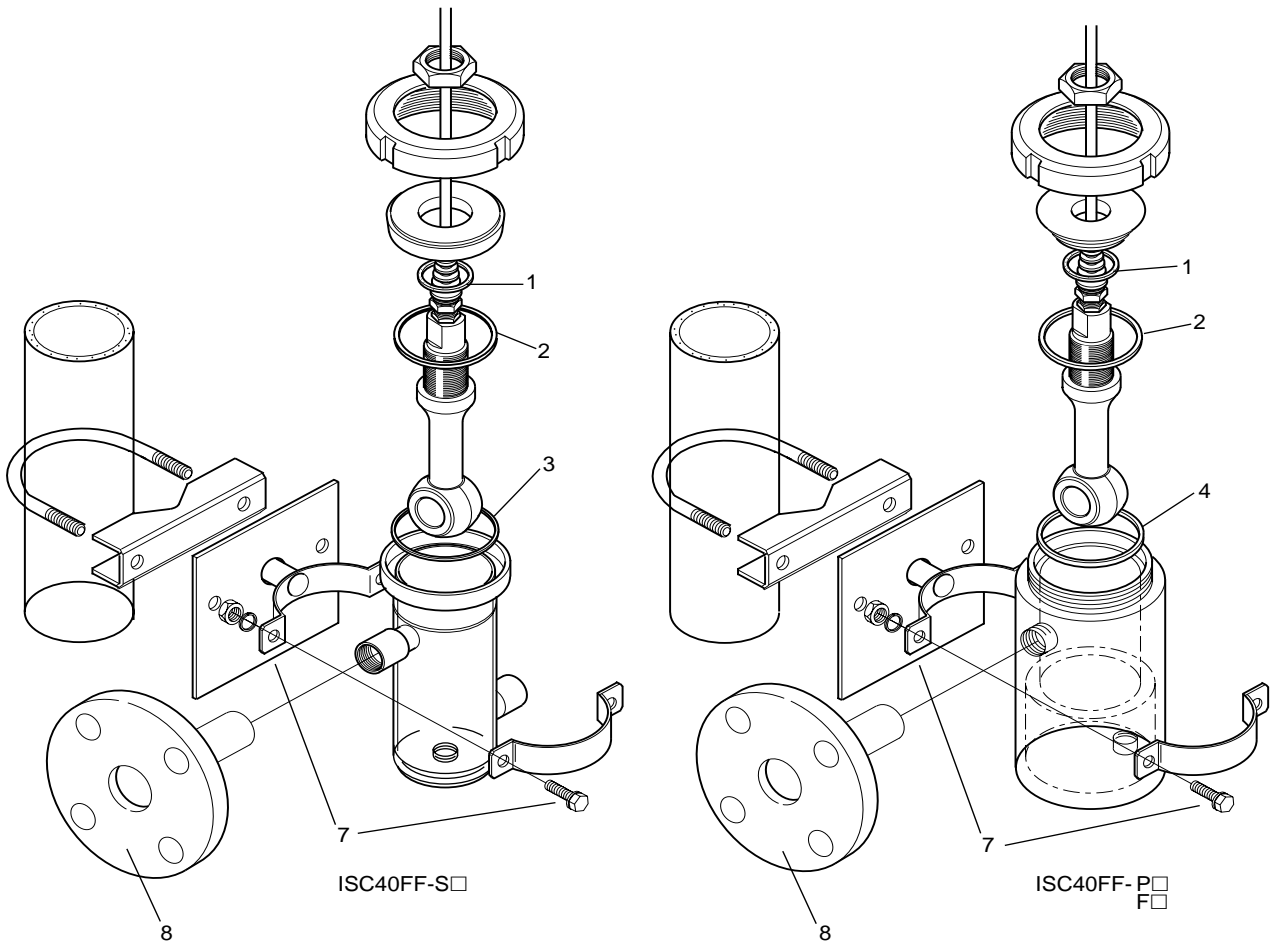

Item	Parts No.	Qty	Description
1	K9414EG	1	O-Ring (Viton,1 pcs.)
	K9414EB	1	O-Ring (Ethylen propylene rubber,1 pcs.) (Option code: /EP)
2	K9414EF	1	O-Ring (Viton,1 pcs.)
	K9414EA	1	O-Ring (Ethylen propylene rubber,1 pcs.) (Option code: /EP)
3	K9414DV	1	U-shaped Gasket (Viton,1 pcs.)
	K9414DD	1	U-shaped Gasket (EPDM) (Option code: /EP)
4	K9414DP	1	O-Ring (Viton,1 pcs.)
	K9414DC	1	O-Ring (EPDM) (Option code: /EP)
7	K1541ZZ	1	Clamp (Option code: /MS)
	K1541ZU	1	Clamp (Option code: /MP)
8	K1543KL	1	Flange (Option code: /FSJ2)
	K1543KM	1	Flange (Option code: /FPJ2)
	K1543KN	1	Flange (Option code: /FFJ2)
	K1521AN	1	Flange (Option code: /FS2)
	K1521AQ	1	Flange (Option code: /FP2)
	K1521AP	1	Flange (Option code: /FF2)

## 5. Model ISC40FS Direct Insertion Adapter

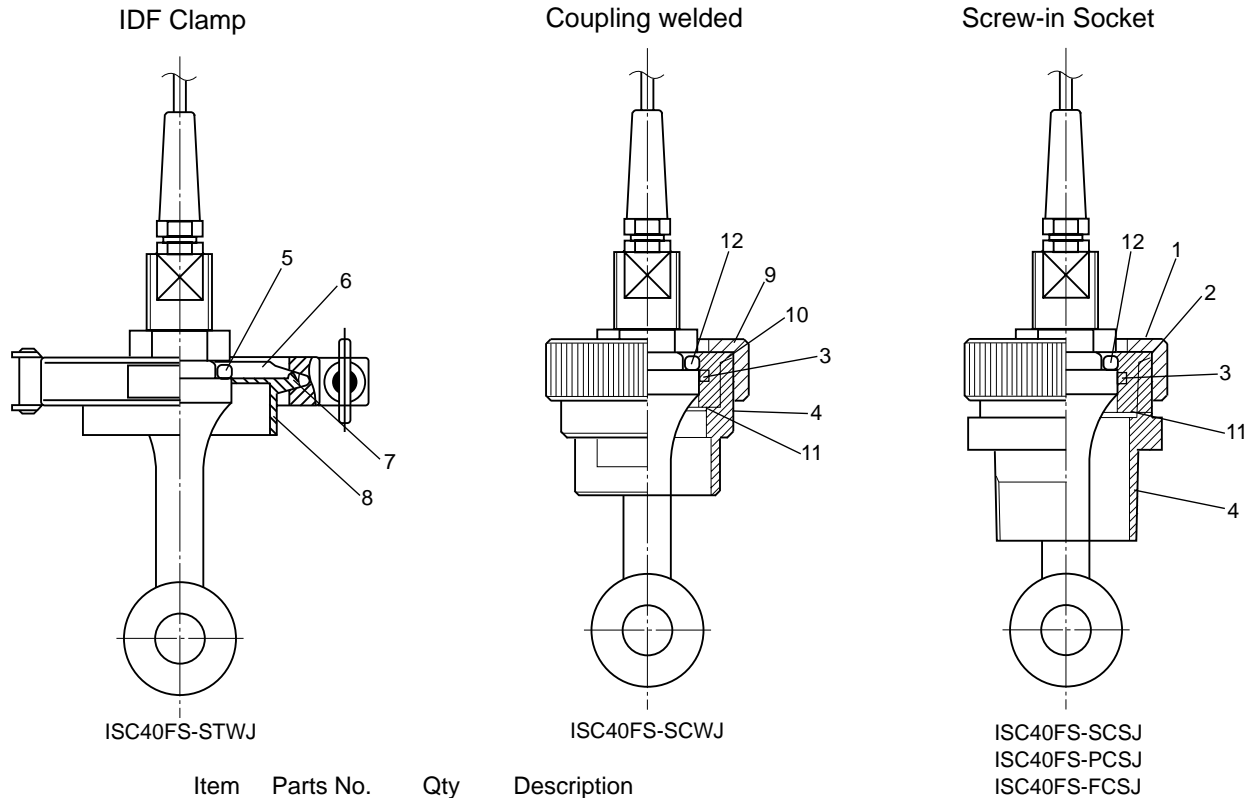

Item	Parts No.	Qty	Description
1	K9414CJ	1	Nut (SUS304)
2	K9414CK	1	Spacer (SUS316)
	K9414CN	1	Spacer (PVC)
	K9414CP	1	Spacer (PVDF)
3	K9414EF	1	O-Ring (Viton, 1 pcs.)
	K9414EA	1	O-Ring (Ethylen propylene rubber, 1 pcs.) (Option code: /EP)
4	K9414CM	1	Socket (SUS316) (Suffix code: -SCSJ)
	K9414CQ	1	Socket (PVC) (Suffix code: -PCSJ)
	K9414CR	1	Socket (PVDF) (Suffix code: -FCSJ)
	K9414CL	1	Socket (SUS316) (Suffix code: -SCWJ)
5	K9414BY	1	U-shaped Gasket (Silicon rubber)
	K9414DE	1	U-shaped Gasket (EPDM) (Option code: /EP)
6	K9414BT	1	Cap
7	K9414BX	1	Gasket (Silicon rubber)
	K9414DG	1	Gasket (EPDM) (Option code: /EP)
8	K9414BV	1	FERRULE (SUS316L)
9	K9414CJ	1	Nut (SUS304)
10	K9414CK	1	Spacer (SUS316)
11	Y9207XB	1	O-Ring (Viton, 1 pcs.)
	K9414DF	1	O-Ring (Ethylen propylene rubber, 1 pcs.) (Option code: /EP)
12	K9414EG	1	O-Ring (Viton, 1 pcs.)
	K9414EB	1	O-Ring (Ethylen propylene rubber, 1 pcs.) (Option code: /EP)

Note: Regarding the ISC40□, ISC40F□ delivered before 1998, see CMPL12D06A02-02EA 2nd Edition.  
Regarding the ISC40□, ISC40F□ Style S2 delivered after 2004, see CMPL12D06A02-03E.

#### 1. Optional Flange of ISC40□ Detector

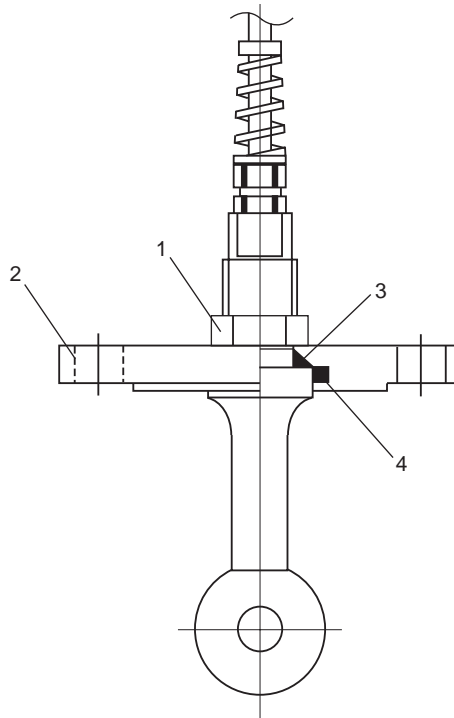

Item	Parts No.	Qty	Description
1	K9667BN	1	Nut
2	—	1	Flange (Option code: /SFD)
	—	1	Flange (Option code: /SFA)
	—	1	Flange (Option code: /SFJ)
	—	1	Flange (Option code: /PFJ)
	—	1	Flange (Option code: /FFJ5)
3	K9414EG	1	O-Ring (Viton, 1pcs.)
	K9414EB	1	O-Ring (Ethylene propylene rubber, 1pcs.) (Option code: /EP)
4	K9414EF	1	O-Ring (Viton, 1pcs.)
	K9414EA	1	O-Ring (Ethylene propylene rubber, 1pcs.) (Option code: /EP)

## 2. Optional Screw-in Adapter of ISC40□ Detector

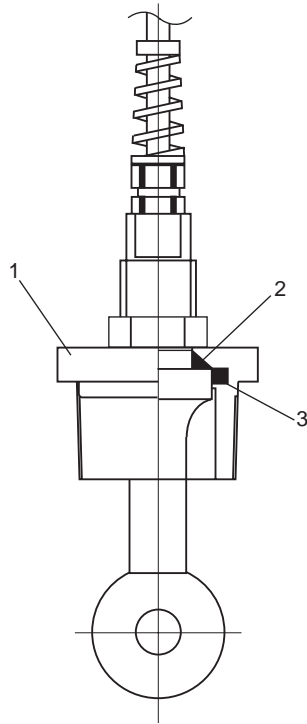

Item	Parts No.	Qty	Description
1	—	1	Adapter (Option code: /SSG)
	—	1	Adapter (Option code: /PSG)
	—	1	Adapter (Option code: /FSJ)
2	K9414EG	1	O-Ring (Viton, 1pcs.)
	K9414EB	1	O-Ring (Ethylen propylene rubber, 1pcs.) (Option code: /EP)
3	K9414EF	1	O-Ring (Viton, 1pcs.)
	K9414EA	1	O-Ring (Ethylen propylene rubber, 1pcs.) (Option code: /EP)

### 3. Model ISC40FD Immersion Holder

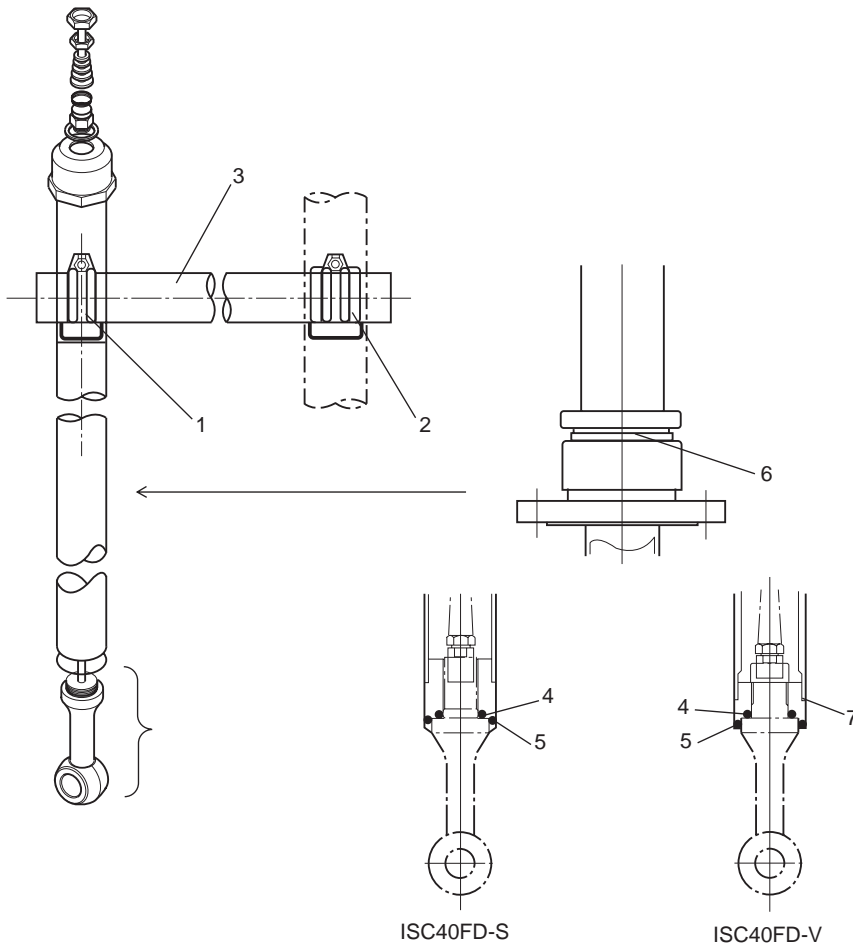

Item	Parts No.	Qty	Description
1	L9813VP	1	Clamp (Option code: /MS1)
	—	2	Clamp (Option code: /MS2)
2	L9813VN	1	Clamp (Option code: /MS1)
	—	2	Clamp (Option code: /MS2)
3	K9144AM	1	Pipe (Option code: /MS1)
	—	2	Pipe (Option code: /MS2)
4	K9414EG	1	O-Ring (Viton, 1pcs.)
	K9414EB	1	O-Ring (Ethylene propylene rubber, 1pcs.) (Option code: /EP)
5	K9414DT	1	O-Ring (Viton, 1pcs.)
	K9414EC	1	O-Ring (Ethylene propylene rubber, 1pcs.) (Option code: /EP)
6	K9414CS	1	Flange Assembly (Option code: /FBJ)
	K9414DM	1	Flange Assembly (Option code: /FBJ, /EP)
	—	1	Flange Assembly (Option code: /FA)
7	L9817NC	1	O-Ring (Viton, 1pcs.)
	K9414DB	1	O-Ring (Ethylene propylene rubber, 1pcs.) (Option code: /EP)

### 4. Model ISC40FF Flow-Through Holder

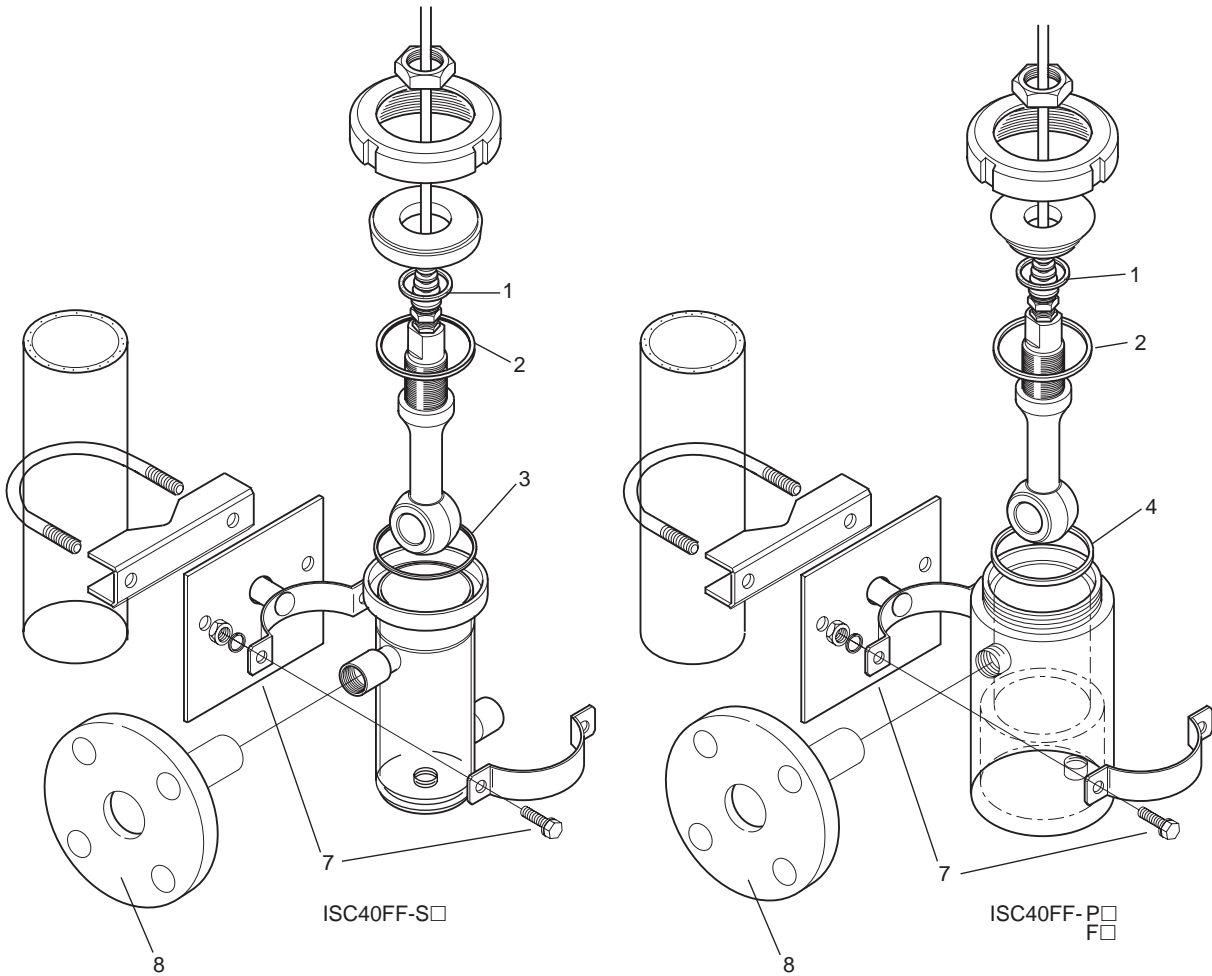

Item	Parts No.	Qty	Description
1	K9414EG	1	O-Ring (Viton, 1pcs.)
	K9414EB	1	O-Ring (Ethylen propylene rubber, 1pcs.) (Option code: /EP)
2	K9414EF	1	O-Ring (Viton, 1pcs.)
	K9414EA	1	O-Ring (Ethylen propylene rubber, 1pcs.) (Option code: /EP)
3	K9414DV	1	Gasket (Viton, 1pcs.)
	K9414DD	1	Gasket (EPDM) (Option code: /EP)
4	K9414DP	1	O-Ring (Viton, 1pcs.)
	K9414DC	1	O-Ring (EPDM) (Option code: /EP)
7	---	1	Clamp (Option code: /MS)
	---	1	Clamp (Option code: /MP)
8	---	1	Flange (Option code: /FSJ2)
	---	1	Flange (Option code: /FPJ2)
	---	1	Flange (Option code: /FFJ2)
	---	1	Flange (Option code: /FS2)
	---	1	Flange (Option code: /FP2)
	---	1	Flange (Option code: /FF2)

## 5. Model ISC40FS Direct Insertion Adapter

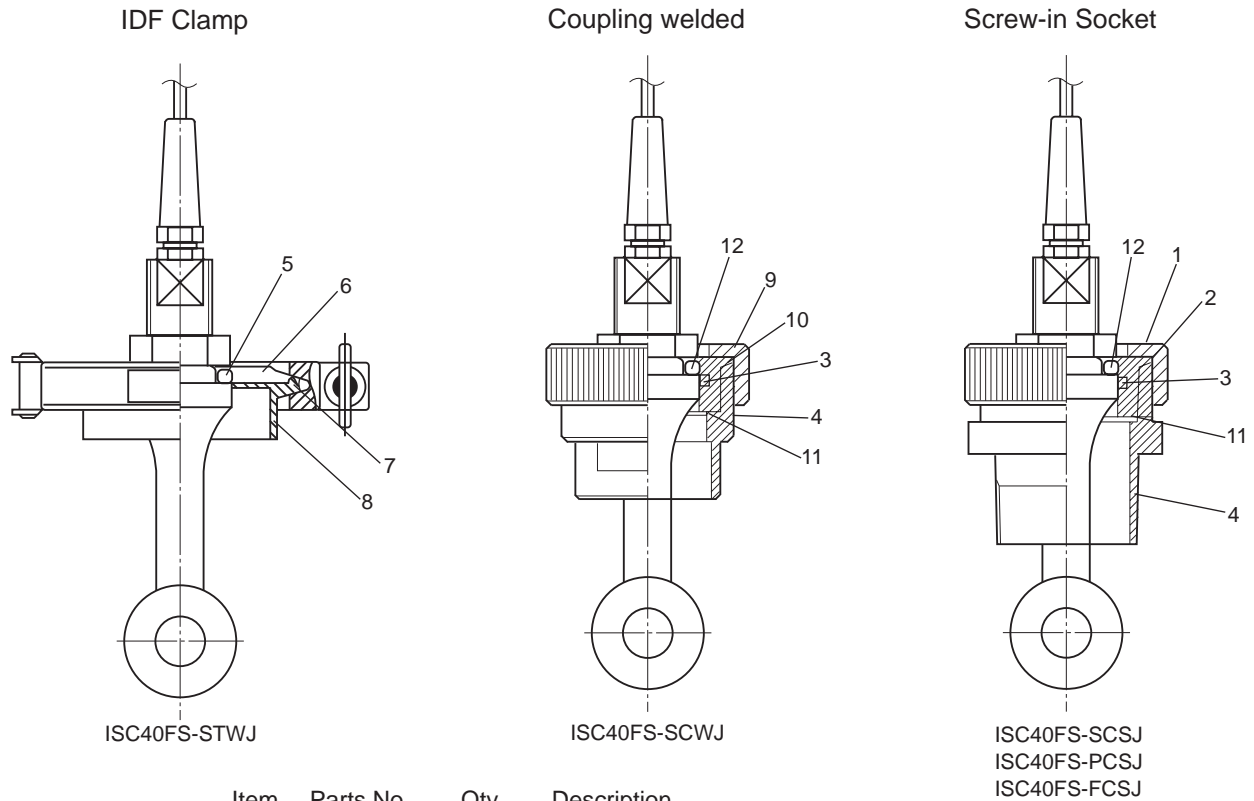

Item	Parts No.	Qty	Description
1	—	1	Nut (SUS304)
2	—	1	Spacer (SUS316)
	—	1	Spacer (PVC)
	—	1	Spacer (PVDF)
3	K9414EF	1	O-Ring (Viton, 1pcs.)
	K9414EA	1	O-Ring (Ethylen propylene rubber, 1pcs.) (Option code: /EP)
4	—	1	Socket (SUS316) (Suffix code: -SCSJ)
	—	1	Socket (PVC) (Suffix code: -PCSJ)
	—	1	Socket (PVDF) (Suffix code: -FCSJ)
	—	1	Socket (SUS316) (Suffix code: -SCWJ)
5	K9414BY	1	U-shaped Gasket (Silicon, 1pcs.)
	K9414DE	1	U-shaped Gasket (EPDM, 1pcs.) (Option code: /EP)
6	—	1	Cap
7	K9414BX	1	Gasket (Silicon, 1pcs.)
	K9414DG	1	Gasket (EPDM, 1pcs.) (Option code: /EP)
8	—	1	FERRULE
9	—	1	Nut
10	—	1	Spacer
11	Y9207XB	1	O-Ring (Viton, 1pcs.)
12	K9414EG	1	O-Ring (Viton, 1pcs.)
	K9414EB	1	O-Ring (Ethylen propylene rubber, 1pcs.) (Option code: /EP)

Note: Regarding the ISC40□, ISC40F□ delivered after 1999, see CMPL12D06A02-02E 4th Edition.

## 1. Optional Flange of ISC40□ Detector

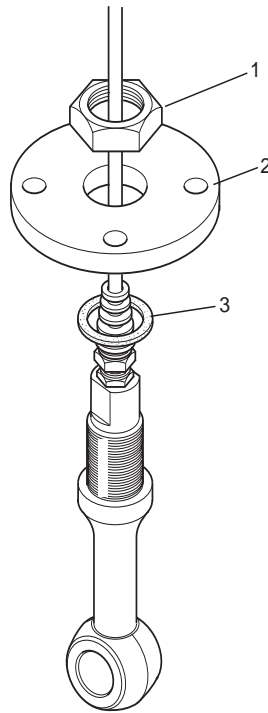

Item	Parts No.	Qty	Description
1	K9667BN	1	Nut
2	—	1	Flange (Option code: /SFD)
	—	1	Flange (Option code: /SFA)
	—	1	Flange (Option code: /SFJ)
	—	1	Flange (Option code: /PFJ)
	—	1	Flange (Option code: /FFJ5)
3	K9414DS	1	Gasket (Viton, 1 pcs.)
	K9414DA	1	Gasket (Ethylen propylene rubber, 1 pcs.)(Option code: /EP)

## 2. Optional Screw-in Adapter of ISC40□ Detector

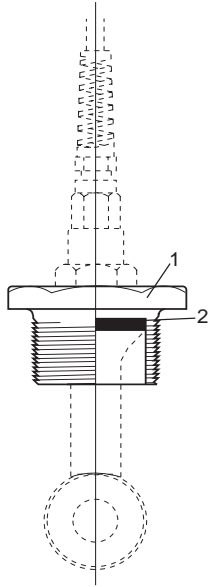

Item	Parts No.	Qty	Description
1	—	1	Adapter (Option code: /SSG)
	—	1	Adapter (Option code: /PSG)
	—	1	Adapter (Option code: /FSJ)
2	K9414DS	1	Gasket (Viton, 1 pcs.)
	K9414DA	1	Gasket (Ethylene propylene rubber, 1 pcs.)(Option code: /EP)

## 3. Model ISC40FD Immersion Holder

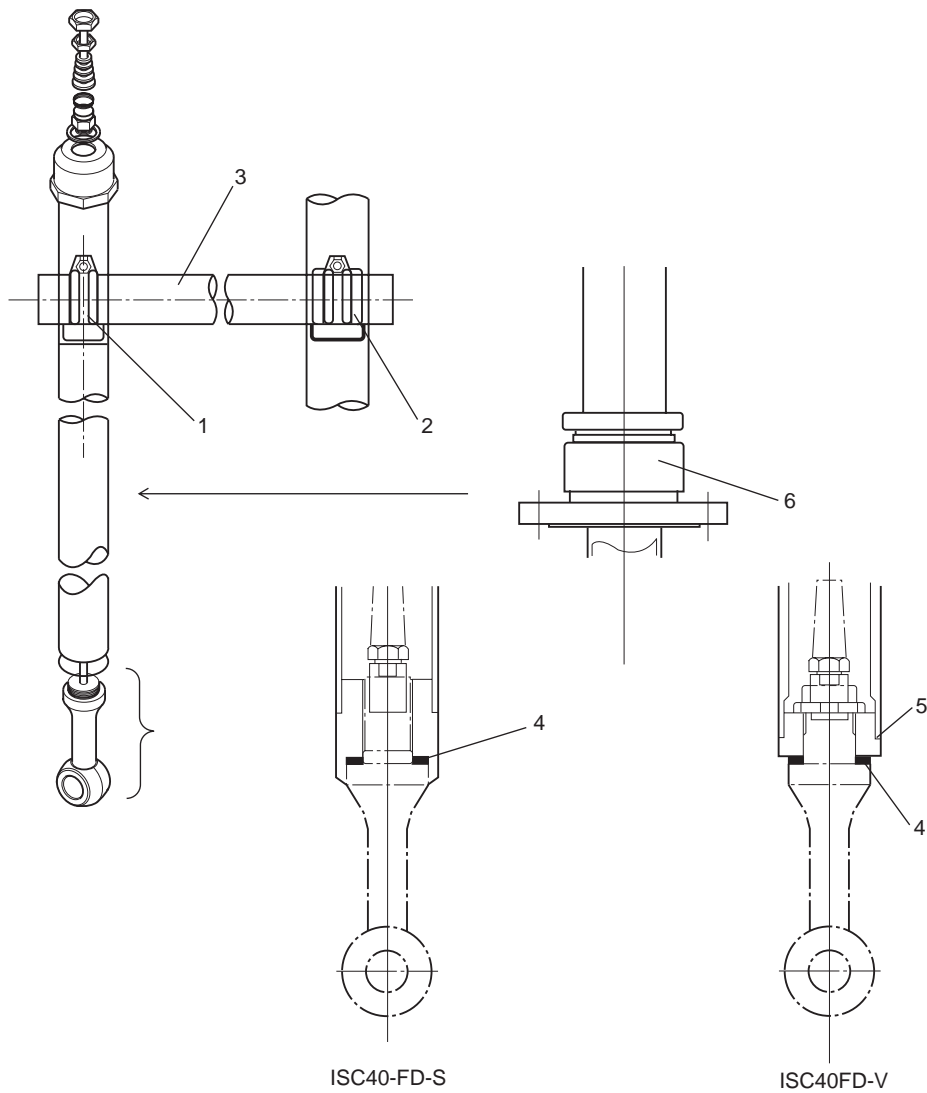

Item	Parts No.	Qty	Description
1	L9813VP	1	Clamp (Option code: /MS1)
	—	2	Clamp (Option code: /MS2)
2	L9813VN	1	Clamp (Option code: /MS1)
	—	2	Clamp (Option code: /MS2)
3	K9144AM	1	Pipe (Option code: /MS1)
	—	2	Pipe (Option code: /MS2)
4	L9817NC	1	Gasket (Viton, 1 pcs.)
	K9414DA	1	Gasket (Ethylene propylene rubber, 1 pcs.)(Option code: /EP)
5	L9817NC	1	O-Ring (Viton, 1 pcs.)
	K9414DB	1	O-Ring (Ethylene propylene rubber, 1 pcs.)(Option code: /EP)
6	K9414CS	1	Flange Assembly (Option code: /FBJ)
	K9414DM	1	Flange Assembly (Option code: /FBJ, /EP)
	—	1	Flange Assembly (Option code: /FA)

## 4. Model ISC40FF Flow-Through Holder

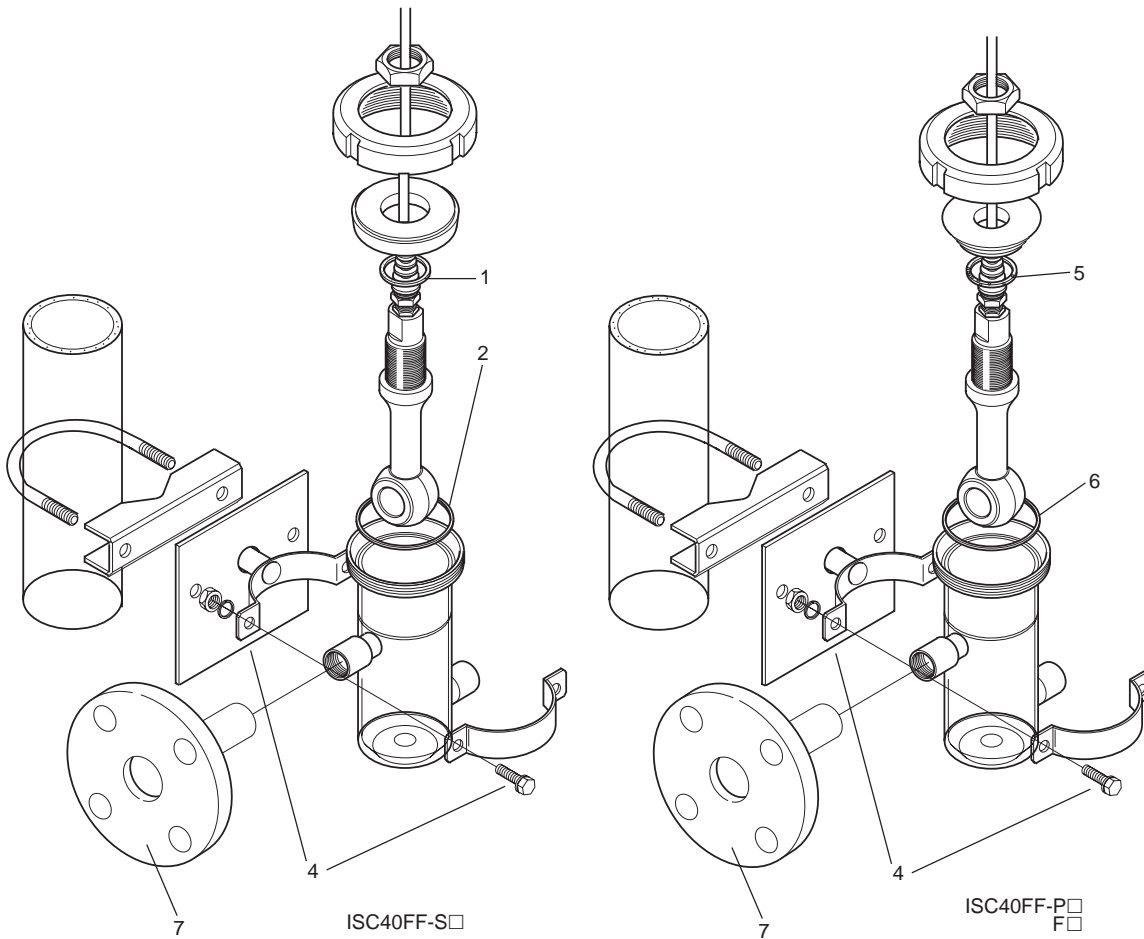

Item	Parts No.	Qty	Description
1	K9414BY	1	Gasket (Silicon, 1 pcs.)
	K9414DE	1	Gasket (Ethylen propylene rubber, 1 pcs.)(Option code: /EP)
2	K9414DV	1	Gasket (Viton, 1 pcs.)
	K9414DD	1	Gasket (Ethylen propylene rubber, 1 pcs.)(Option code: /EP)
4	—	1	Clamp (Option code: /MS)
	—	1	Clamp (Option code: /MP)
5	K9414DS	1	Gasket (Viton, 1 pcs.)
	K9414DA	1	Gasket (Ethylen propylene rubber, 1 pcs.)
6	K9414DP	1	O-Ring (Viton, 1 pcs.)
	K9414DC	1	O-Ring (Ethylen propylene rubber, 1 pcs.)
7	—	1	Flange (Option code: /FSJ2)
	—	1	Flange (Option code: /FPJ2)
	—	1	Flange (Option code: /FFJ2)
	—	1	Flange (Option code: /FS2)
	—	1	Flange (Option code: /FP2)
	—	1	Flange (Option code: /FF2)

## 5. Model ISC40FS Direct Insertion Adapter

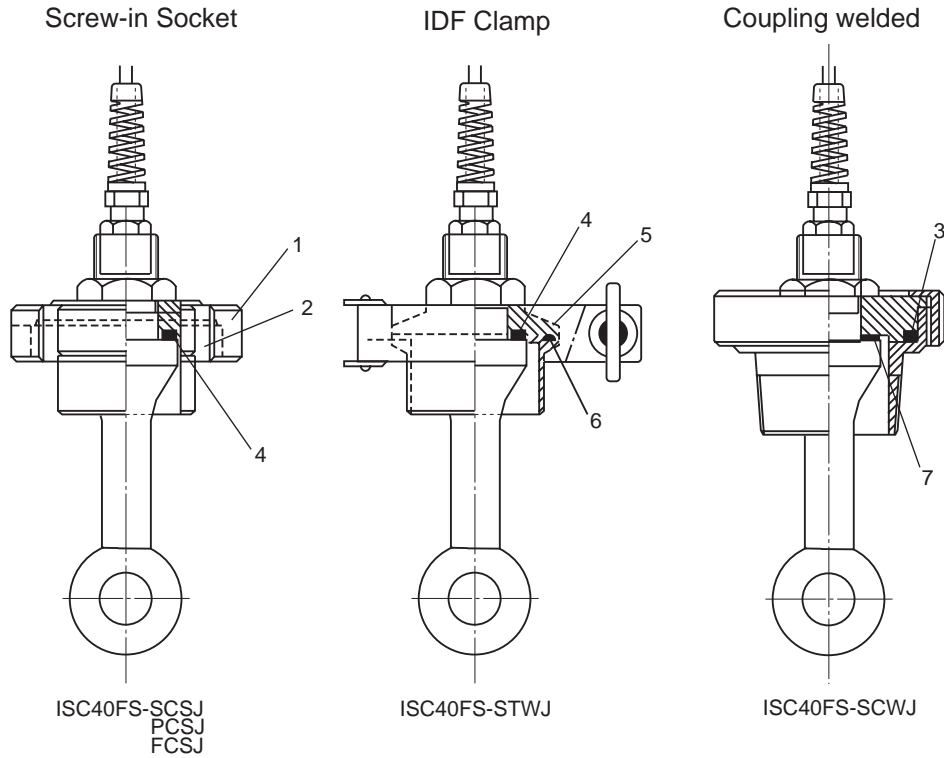

Item	Parts No.	Qty	Description
1	—	1	Nut
2	—	1	Spacer
3	K9414DP	1	O-Ring (Viton, 1 pcs.)
	K9414DC	1	O-Ring (Ethylen propylene rubber, 1 pcs.) (Option code: /EP)
4	K9414BY	1	Gasket (Silicon rubber, 1 pcs.)
	K9414DE	1	Gasket (Ethylen propylene rubber, 1 pcs.) (Option code: /EP)
5	—	1	Cap
6	K9414BX	1	Gasket (Silicon rubber, 1 pcs.)
	K9414DG	1	Gasket (Ethylen propylene rubber, 1 pcs.) (Option code: /EP)
7	K9414DS	1	Gasket (Viton, 1 pcs.)
	K9414DA	1	Gasket (Ethylen propylene rubber, 1 pcs.) (Option code: /EP)

# Revision Record

---

Manual Title : ISC40□J Inductive Conductivity Sensors, ISC40F□J Holders, Adapter, BA20 Terminal Box, WF10J Extension Cable

Manual Number : IM 12D06B02-01E

---

<b>Edition</b>	<b>Date</b>	<b>Remark (s)</b>
1st	May. 2006	Newly published
2nd	Jan. 2008	Ring terminals added to ISC40□J for ISC450G converter.
3rd	Jun. 2008	ISC40SJ-TT explosionproof sensor added.

---

---

User's Manual	ISC40□J	Inductive Conductivity Sensors	Supplement
	ISC40F□J	Holder, Adapter	
	BA20	Terminal Box	
	WF10J	Extension Cable	

---

Thank you for selecting our Model ISC40 Inductive Conductive Detector.

The User's Manual IM 12D06B02-01E 3rd edition supplied with this product has been revised as follows.  
Please make a note in your copy.

Addition/Correction

- Pi Manual No. of FLXA21 added.
- P1-1 to 1-2 Some of Figure 1.1 and 1.2 modified.
- P2-1 FLXA21 added to combination of detector and converters.

# ◆ PREFACE

Thank you for purchasing our inductive conductivity measurement system.

Contents of This Manual

This manual describes the method of installing, setting the operation conditions.

ISC40□J inductive conductivity detector

ISC40F□J Holders, Adapter

BA20 junction terminal box, WF10J extension cable

To ensure that this measurement system can be operated safely and also exhibit its full performance, be sure to read this manual before use.

This manual does not describe the units in Table shown below which are the component units of the inductive conductivity transmitter system. Each of these units comes with an instruction manual, so read the applicable manuals for details of the units concerned.

Manual Name	IM No.
ISC202 2-wire Inductive Conductivity Transmitter	IM 12D06A03-01E
ISC202SJ TIIS Type Intrinsic-safe 2-wire Inductive Conductivity Transmitter	IM 12D06A03-11E
FLXA21 2-wire Transmitter	IM 12A01A02-01E
ISC402G 4-wire Inductive Conductivity Converter	IM 12D6D1-E
ISC450G 4-wire Inductive Conductivity Converter	IM 12D06D05-01E

T01E.EPS

Caution for the ISC40SJ-TT explosionproof type sensor shown as below.

The temperature of the sample solution in contact with ISC40SJ-TT sensor should be the range of -10 to +105°C.

	<b>WARNING AVERTISSEMENT 静電気注意</b>
爆発のおそれがあるので、乾布による摩擦等、 静電気が発生する操作を行わないでください。	
POTENTIAL ELECTROSTATIC CHARGING HAZARD - SEE INSTRUCTIONS	
DANGER POTENTIEL DE CHARGES ÉLECTROSTATIQUES - VOIR INSTRUCTIONS	

Ui	Ii	Pi	Li	Ci
14.4V	20mA	190mW	28.6mH	0.2μF
注 取扱説明書(IM 12D06)参照				
EXPLOSION PROOF			EX ia IIC T4	
AMB.TEMP. -10 ~ 60°C			PROCESS TEMPERATURE 105°C	

# 1. Introduction

## 1.1 Features

The model ISC40□J inductive conductivity detector is designed for use with the model ISC202, FLXA21/ISC402G, ISC450G transmitter/converter. This revolutionary conductivity measuring system features  $\pm 0.5\%$  accuracy over a wide range of conductivity values (1 $\mu$ S/cm to 1,999 mS/cm) and process temperatures (-10 to 130 °C, -10 to 105 °C for ISC40SJ-TT) without changing cell constant or recalibration.

The model ISC40□J sensor is rugged steel-backed sensor encapsulated with the highest quality engineering plastic known today (Victrex PEEK) for long service life in both abrasive and chemically corrosive processes.

The stainless steel mounting thread and the Viton gasket allow safe and reliable installation. The long insertion depth allows for installation of the sensor either by a bulkhead mounting through a flange or tank wall, or by using one of the process adapter kits (e.g. for flow-through or immersion service).

The large bore, greater than 16 mm , gives long-term stability, preventing measuring errors caused by coating or plugging. The large bore also offers fast response even at low flow rates.

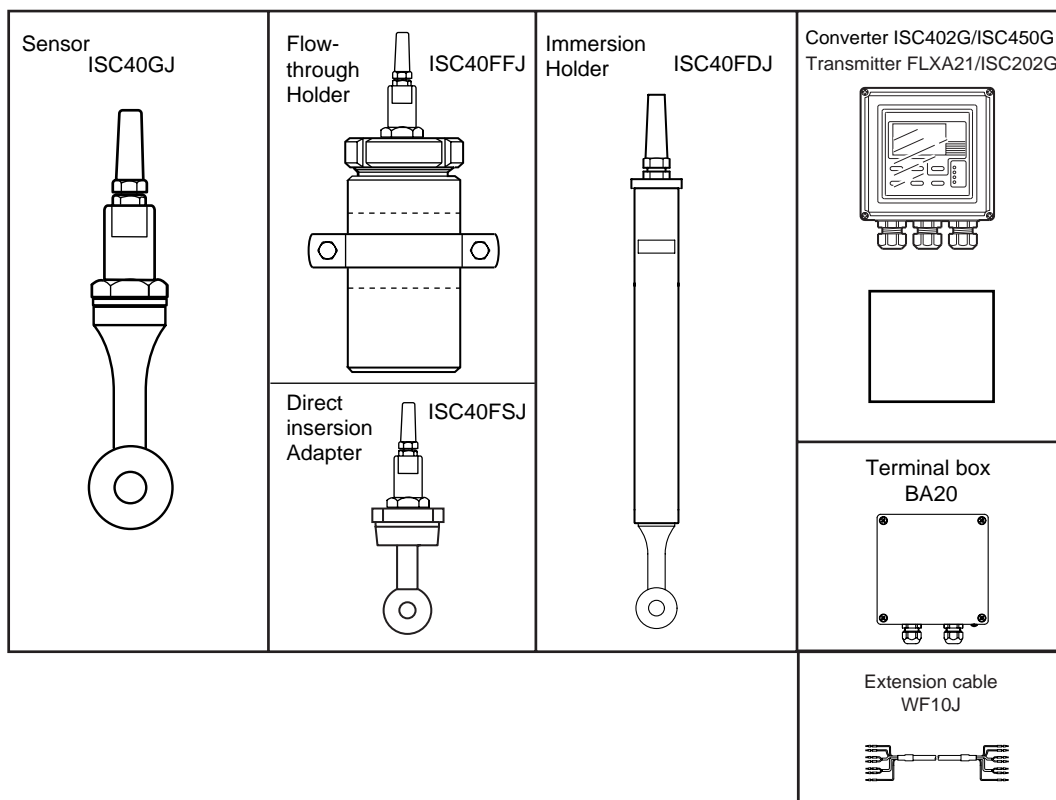

Fig01.eps

**Figure 1.1 Non-explosionproof System**

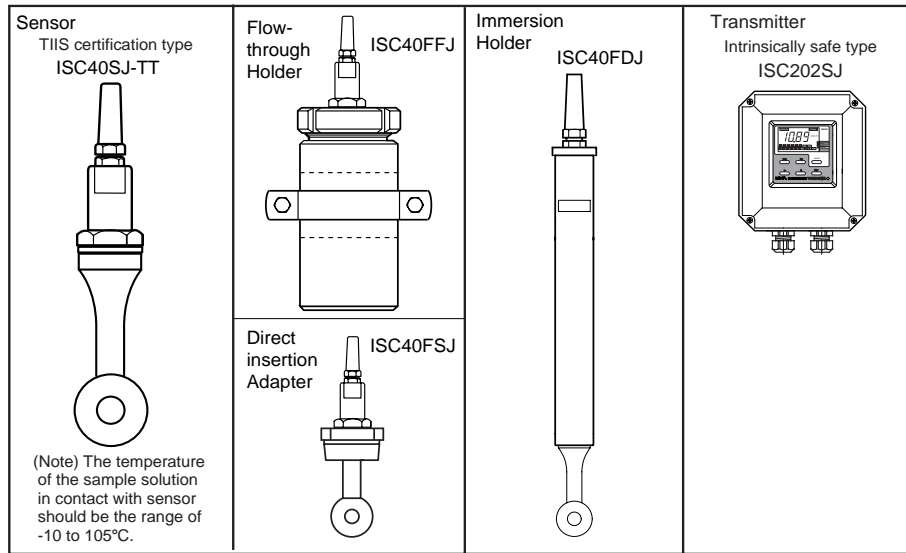

Fig02.eps

**Figure 1.2 Explosionproof System**

## 1.2 Measurement principle

Contrary to contact electrode conductivity, the EXA ISC series analyses the conductivity without any contact between electrodes and process fluid. The measurement is based on inductive coupling of 2 ring transformers (Toroids) by the liquid.

The converter supplies a reference voltage at a high frequency to the "drive coil". The core of this coil is of a high permeability magnetic material, and a strong magnetic field is generated in the toroid.

The liquid passes through the hole in the toroid and can be considered as a "one turn" secondary winding.

The magnetic field will induce a voltage in this secondary winding. The induced current in the liquid winding is proportional to this voltage and the conductance of the liquid "one turn winding" is according to Ohm's law.

The conductance (1/R) is proportional to the specific conductivity and a constant factor that is determined by the geometry of the sensor (length divided by surface area of the hole in the toroid) and the installation of the sensor.

There are 2 toroids mounted in the "doughnut" shaped sensor. The liquid also flows through the second toroid and therefore the liquid turn can be considered as a primary winding of the second ring transformer.

The current in the liquid will create a magnetic field in the second toroid. The induced voltage being the result of this magnetic field can be measured as an output.

The output voltage of this "receive coil" is therefore proportional to the specific conductivity of the process liquid.

### Inductive conductivity measurement principle

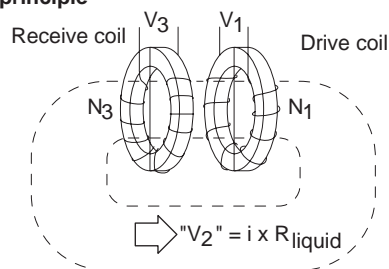

F1.2E.eps

**Figure 1.3 Measurement Principle**

## 2. Specifications

---

### 2.1 General Specifications

#### 2.1.1 ISC40□J Inductive Conductivity Sensor

Compatibility : ISC40GJ is compatible with ISC202G/FLXA21 Inductive Conductivity Transmitter and ISC402G/ISC450G Converter.

ISC40SJ-TT is compatible with ISC202SJ Inductive Conductivity Transmitter.

Measurement Range : 1  $\mu$ S/cm to 1999 mS/cm

Output Span : Min. 100  $\mu$ S/cm ; Max. 1999 mS/cm

Process Temperature : -10 to 130°C for continuous exposure. -10 to 105°C for

ISC40SJ-TT. Suitable for steam-sterilisable applications. (Notes 1 and 2)

Process Pressure : Pressure resistance 2 MPa max. (Note 1)

Process Flow Volume : Max. 5 m/s

Wetted materials

Sensor : PEEK (polyether ether ketone)

Gaskets : Viton (fluorine rubber)

Adapter (additional machining) : SUS316, PVC or PVDF

Non-wetted materials

Sensor Screws : SUS304

Retaining Nuts : SUS304

Cables : Weatherproof vinyl

Process Connection : Mounting with G3/4 screw at top of Sensor, or connection using process adapter or holder (flow-through or submersion type)

Process Adapter : JIS 10K 50 RF flange (Material: SUS316)

JIS 10K 50 FF flange (Material: PVC or PVDF)

DIN PN16 DN50 flange (Material: SUS316)

ANSI Class150 2 flange (Material: SUS316)

Screw-in adapter (R2 screw Material: Can be selected from SUS316, PVC or PVDF)

Cable Length : 5 m, 10 m, 15 m, 20 m

Extension cable of up to 50 m can be used. (detector cable and extension cable)

Dimensions : Refer to 2.3, "External Dimensions".

Weight : Sensor Approx. 0.6 kg

Note 1: The process temperature and pressure differ depending upon the adapter or holder used.

Note 2: The temperature compensation range of the transmitter is between -10 and 130°C

Note 3: Do not submerge the sensor itself in process water, as the seams between the mold and the metal of the sensor are not waterproof. Since a temperature sensor is imbedded in the PEEK molded sensor, its response speed is not fast, Install another temperature sensor if necessary.

#### ISC40SJ-TT Intrinsically safe type sensor

TIIS certification sensor should be used with ISC202SJ

Protection Concept and Adapter Group: Ex ia IIC T4

Intrinsic safe rating:

$U_i=14.4$  V,  $I_i=20$  mA,  $P_i=190$  mW,  $L_i=28.6$  mH,

$C_i=0.2$   $\mu$ F

Environment and operational conditions

The temperature of the sample solution in contact with sensor should be the range of -10 to 105°C.