

# MESO-H



MESO-HX

## Universal HART-compatible 2-wire Transmitters



MESO-H

MESO-H/-HX are smart and universal 2-wire in-head transmitters for temperature and other measurement applications. MESO-H/-HX are fully HART-compatible, with communication through the HART protocol.

- Utilizes HART Protocol for remote configuration and monitoring
- Communicates with HART Communicator or PC via modem
- Fully universal, linearized and isolated
- Accepts RTD, T/C, mV and  $\Omega$
- Sensor error correction
- Easy wiring, large center hole
- 50 point linearization – any sensor can be matched
- Consistent sensor break function
- Full access to all features while in operation
- Low sensor isolation detection
- MEPRO, easy-to-use Windows configuration software
- Integrated in Emerson AMS and Siemens PDM systems



### Input connections

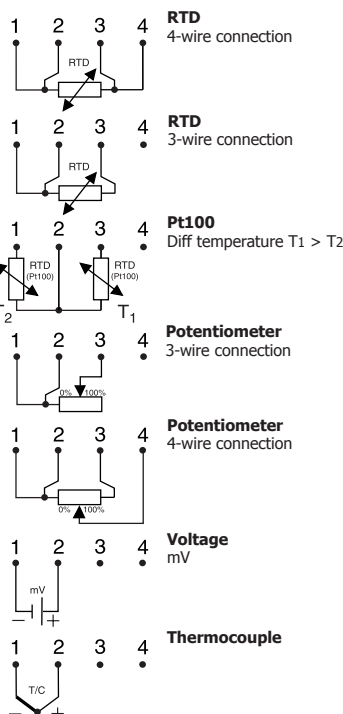

### Output connections

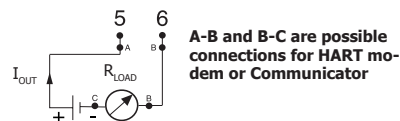

### Specifications:

<b>Input RTD and Resistance</b>	3-,4-wire connection
Pt100 <sup>1)</sup> and D100 <sup>2)</sup>	-200 to +1000 °C / -328 to +1832 °F
Pt1000 <sup>1)</sup>	-200 to +200 °C / -328 to +392 °F
PtX 10 ≤ X ≤ 1000 <sup>1)</sup>	Upper range depending on X value
Ni100 <sup>3)</sup>	-60 to +250 °C / -76 to +482 °F
Ni1000 <sup>3)</sup>	-60 to +150 °C / -76 to +302 °F
Potentiometer / resistance	0 to 2000 $\Omega$
<b>Input Thermocouples</b>	AE, B, E, J, K, L, N, R, S, T, U
<b>Input Voltage</b>	-10 to +500 mV
<b>Sensor failure / Low isolation</b>	User definable output
<b>Adjustments - Zero</b>	Any value within range limits
<b>Adjustments - Minimum spans</b>	
Pt100, Pt1000, Ni100, Ni1000	10°C / 18°F
Potentiometer	10 $\Omega$
T/C, mV	2 mV
<b>Output</b>	4-20 / 20-4 mA
<b>Operating temperature</b>	-40 to +85°C / -40 to +185°F
<b>Galvanic isolation</b>	1500 VAC, 1 min
<b>Power supply</b>	MESO-H 10 to 42 VDC MESO-HX 12 to 30 VDC
<b>Intrinsic safety</b>	
MESO-HX ATEX:	II 1 G EEx ia IIC T4-T6
MESO-HX FM:	IS Class I-III, DIV 1, GP A-D, G
MESO-HX CSA:	Class I, Groups A-D; Class II, Group G; Class III
<b>Typical accuracy</b>	±0.1% of temperature span
<b>Connection head</b>	DIN B or larger

<sup>1)</sup>IEC 60751,  $\alpha=0.00385$  <sup>2)</sup>Pt100 acc. to JIS 1604,  $\alpha=0.003916$  <sup>3)</sup>IEC 60751

### Output load diagram

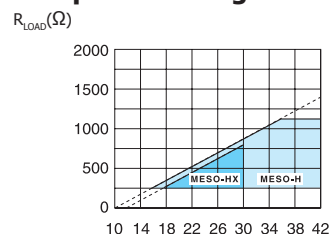

### Dimensions

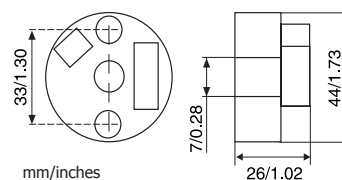

### Ordering information

MESO-H	70MEH00001
MESO-HX (ATEX)	70MEHX00001
MESO-HX (FM, CSA)	70MEHX1001
HART PC modem RS232	70MEM00001
HART PC modem USB	70MEM00003
Software CD	70CDSOFT01
Configuration	70CAL00001