

# EE66 Series

## Air Velocity Transmitter for Measurement of Lowest Velocity

EE66 air velocity transmitter series are designed for high accuracy measurement of lowest air velocities. It is the ideal solution for laminar flow control and special ventilation applications. The E+E thin film sensor is operating on an innovative hot film anemometer principle. This guarantees excellent accuracy for air velocity down to almost 0.15m/s, which is not possible for conventional anemometers with commercial temperature sensors or NTC bead thermistors.

The E+E sensor is much more insensitive to pollution than all other anemometer principles. This increases reliability and reduces maintenance costs.

EE66 series are available with current or voltage output, the measuring range and the response time can be selected with jumpers by the user.

Low angular dependence enables easy, cost-effective installation.

An integrated LC display and a version with remote sensing probe are also available.



EE66 - A / B



EE66 - C

### Typical Applications

**clean room control**  
**laminar flow control**

### Features

**measurement down to 0m/s**  
**low angular dependence**  
**easy installation**

### Technical Data

#### Measuring values

Working range <sup>1)</sup>	0...1m/s (0...200ft/min)	
	0...1.5m/s (0...300ft/min)	
	0...2m/s (0...400ft/min)	
Output <sup>1)</sup>	0 - 10 V	-1mA < I <sub>L</sub> < 1 mA
	0...1m/s / 0...1.5m/s / 0...2m/s	4 - 20 mA
Accuracy at 20°C (68°F), 45% RH and 1013 hPa	0.15...1m/s (30...200ft/min)	± (0.04m/s / 7.9ft/min + 2 % of m. v.)
	0.15...1.5m/s (30...300ft/min)	± (0.05m/s / 9.8ft/min + 2 % of m. v.)
	0.15...2m/s (30...400ft/min)	± (0.06m/s / 11.8ft/min + 2 % of m. v.)
Response time τ <sub>90</sub> <sup>1) 2)</sup>	typ. 4 sec. or typ. 0.7 sec.	(at constant temperature)

#### General

Power supply	24V AC/DC ± 20 %
Current consumption for AC supply	max. 150 mA
	for DC supply max. 90 mA
Angular dependence	< 3 % of measurement at   Δα   < 10°
Cable gland	M16x1.5 cable Ø 4.5 - 10 mm (0.18 - 0.39")
Electrical connection	screw terminals max. 1.5 mm <sup>2</sup> (AWG 16)
Electromagnetic compatibility	EN61326-1
	EN61326-2-3
Housing / protecting class	Polycarbonate / IP65, Nema 4; with LC display: IP40; remot sensor probe: IP20



1) Selectable by jumper

2) Response time τ<sub>90</sub> is measured from the beginning of a step change of air velocity to the moment of reaching 90% of the step.

Temperature range	working temperature probe	-25...50°C (-13...122°F)
	working temperature electronic	-10...50°C (14...122°F)
	storage temperature	-30...60°C (-22...140°F)

## Dimensions (mm)

1 mm = 0.03937" / 1" = 25.4 mm

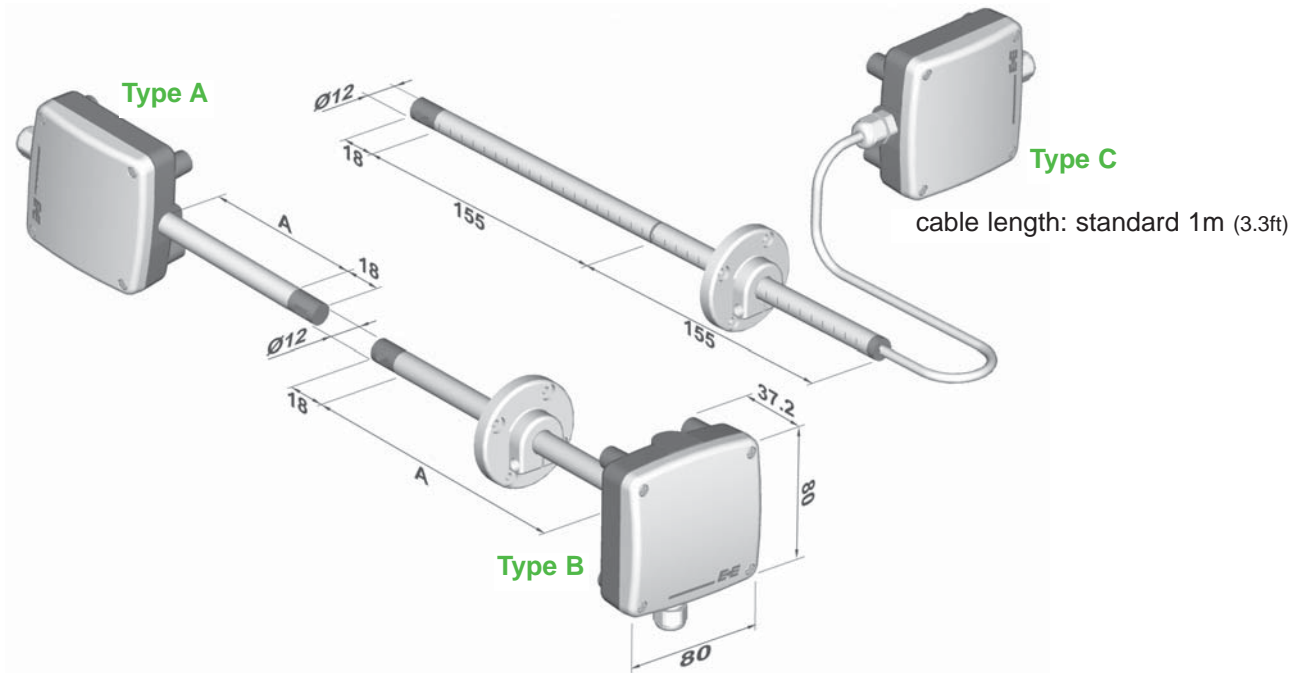

## Connection Diagram

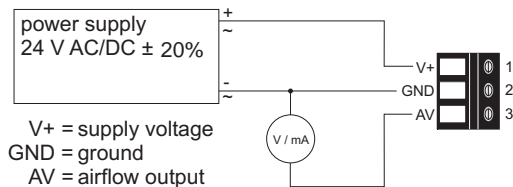

## Ordering Guide

MODEL	HOUSING	PROBE LENGTH (according to "A")	CABLE LENGTH (Type C only)	DISPLAY
velocity (V)	wall mounting (A)	100mm (3.9") (3)	1m (3.3ft) (no code)	without display (no code)
	duct mounting (B)	200mm (7.9") (5)	2m (6.6ft) (K200)	with display (D02)
	remote sensor probe (C)	others (x)	5m (16.4ft) (K500) 10m (32.8ft) (K1000)	
EE66-				

## Order Example

### EE66-VB5-D02

model:  
housing:  
probe length:  
display:

velocity  
duct mounting  
200mm (7.9")  
with LC display

## Accessories

- Snap in - mounting flange for wall mounting (HA010204)
- Snap in - mounting flange for duct mounting (HA010205)