



RS232/485 –TCP/IP converter

TPC2RS

Ver. 01A- GB

- 1: INTRODUCTION.....5**
 - 1.1 NETWORK PROTOCOLS.....5
 - 1.1.1 Packing Algorithms.....6
 - 1.1.2 Ethernet (MAC) Address.....6
 - 1.1.4 Port Number.....6
- 2: INSTALLATION7**
 - 2.1 PRODUCT DESCRIPTION.....7
 - 2.1.1 Serial Interface.....7
 - 2.1.2 Network Interface.....7
 - 2.1.3 LEDs.....7
 - 2.1.4 Product Information Label.....8
 - 2.2 INSTALLING THE TCP2RS8
- 3: GETTING STARTED9**
 - 3.1 DEFAULT IP ADDRESS.....9
 - 3.2 IP ADDRESS CONFIGURATION10
 - 3.2.1 Network Port Login (1).....10
 - 3.2.2 Network Port Login (2).....10
 - 3.2.3 Serial Port Login.....11
- 4: CONFIGURATION.....13**
 - 4.1 NETWORK CONFIGURATION13
 - 4.1.1 Using a Web Browser13
 - 4.1.2 Using a Telnet Connection.....14
 - 4.2 SERIAL CONFIGURATION14
 - 4.3 CONFIGURATION PARAMETERS14
 - 4.4 SERVER CONFIGURATION16
 - 4.4.1 IP Address.....16
 - 4.4.2 Gateway Address16
 - 4.4.3 Netmask.....16
 - 4.4.4 Telnet Configuration Password16
 - 4.5 SERIAL CHANNEL (PORT) CONFIGURATION.....17
 - 4.5.1 Baud Rate.....17
 - 4.5.2 Interface Mode.....17
 - 4.5.3 Flow Control.....18
 - 4.5.4 Port Number.....18
 - 4.5.5 Connect Mode18
 - 4.5.6 Remote IP Address.....20
 - 4.5.7 Remote Port21
 - 4.5.8 Disconnect Mode21

4.5.9	<i>Flush Mode (Buffer Flushing)</i>	21
4.5.10	<i>Pack Control</i>	22
4.5.11	<i>Inactivity (Disconnect) Timeout</i>	23
4.5.12	<i>Send Characters</i>	23
4.5.13	<i>Telnet Terminal Type</i>	23
4.5.14	<i>Channel (Port) Password</i>	23
4.6	FACTORY DEFAULT SETTINGS.....	24
4.7	EXIT CONFIGURATION MODE.....	24
5:	USING THE TCP2RS	25
5.1	COMM PORT REDIRECTOR.....	25
5.1.1	<i>Redirector Setup</i>	25
5.1.2	<i>TCP2RS Configuration</i>	25
5.2	MONITOR MODE.....	26
5.2.1	<i>Via the Serial Port</i>	26
5.2.2	<i>Via the Network</i>	26
5.2.3	<i>Monitor Mode Commands</i>	27
A:	CONTACT INFORMATION	29
A.1	PROBLEM REPORT PROCEDURE.....	29
A.2	FULL CONTACT INFORMATION.....	30
B:	BINARY TO HEXADECIMAL CONVERSION.....	31
C:	PINOUTS	32
C.1	ETHERNET CONNECTOR.....	32
C.2	SERIAL CONNECTOR.....	32
C.3	SERIAL AND ETHERNET WIRES.....	33
	<i>Standard Serial Wire</i>	33
D:	UPDATING FIRMWARE	35
D.1	OBTAINING FIRMWARE.....	35
D.2	RELOADING FIRMWARE.....	35
D.2.1	<i>VIA TFTP</i>	35
D.2.2	<i>VIA ANOTHER DEVICE SERVER</i>	36
D.2.3	<i>VIA THE SERIAL PORT</i>	36
E:	TECHNICAL SPECIFICATIONS	38
E.1	CPU, MEMORY CONTROLLERS.....	38
E.2	SERIAL INTERFACE.....	38
E.3	NETWORK INTERFACE.....	38
E.4	POWER SUPPLY.....	38
E.5	DIMENSIONS.....	38
E.6	ENVIRONMENTAL LIMITATIONS.....	38
E.6.1	<i>Temperature</i>	38
E.6.2	<i>Altitude</i>	39

E.6.3 Relative Humidity39

F: IP ADDRESSING40

F.1 CLASS A NETWORK40

F.2 CLASS B NETWORK.....40

F.3 CLASS C NETWORK.....41

F.4 CLASS D NETWORK41

F.5 CLASS E NETWORK.....41

F.6 NETWORK ADDRESS.....41

F.7 BROADCAST ADDRESS41

F.8 IP NETMASK42

F.9 PRIVATE IP NETWORKS AND THE INTERNET42

F.10 NETWORK RFCs43

1: Introduction

The TCP2RS Device Server connects serial devices to Ethernet networks using the IP protocol family (TCP for connection-oriented stream applications and UDP for datagram applications). A few of the different types of serial devices supported are listed below:

- ◆ Time/Attendance Clocks and Terminals
- ◆ ATM Machines
- ◆ CNC Controllers
- ◆ Data Collection Devices
- ◆ Universal Power Supply (UPS) Management Units
- ◆ Telecommunications Equipment
- ◆ Data Display Devices
- ◆ Security Alarms and Access Control Devices
- ◆ Handheld Instruments
- ◆ Modems

The TCP2RS connects these devices through a TCP data channel or through a Telnet connection to computers or another Device Server. Datagrams can be sent by UDP.

1.1 Network Protocols

The TCP2RS uses IP protocol for network communications. The supported protocols are ARP, UDP, TCP, ICMP, Telnet, TFTP, DHCP, HTTP, and SNMP. For connections to the serial port, TCP, UDP or Telnet protocols are used. Firmware updates can be performed using TFTP.

The Internet Protocol (IP) defines addressing, routing, and data block handling over the network. The Transmission Control Protocol (TCP) assures that no data is lost or duplicated, and that everything sent to the connection arrives correctly at the target.

For typical datagram applications in which devices interact with other devices without maintaining a point-to-point connection, User Datagram Protocol (UDP) is used.

1.1.1 Packing Algorithms

Two software selectable packing algorithms define how and when packets are sent to the network. The standard algorithm is optimized for applications in which the TCP2RS is used in a local environment, allowing for very small delays for single characters while keeping the packet count low. The alternate packing algorithm minimizes the packet count on the network, and is especially useful in applications in a routed Wide Area Network (WAN). Adjusting parameters in this mode can economize the network data stream.

1.1.2 Ethernet (MAC) Address

The Ethernet address is also referred to as the hardware address or the MAC address. The first three bytes of the Ethernet Address are fixed. The fourth, fifth, and sixth bytes are unique numbers assigned to each TCP2RS.

Table 1-1: Sample Ethernet Address

00-20-4A-14-01-18 or 00:20:4A:14:01:18

1.1.3 Internet Protocol (IP) Address

Every device connected to an IP network must have a unique IP address. This address is used to reference the specific TCP2RS. See Appendix F for more information on IP Addressing.

1.1.4 Port Number

Every TCP connection and every UDP datagram is defined by a destination IP address and a port number. For example, a Telnet application commonly uses port number 23. A port number is similar to an extension on a PBX system.

2: Installation

This chapter describes the TCP2RS and shows how to install it on a basic network.

2.1 Product Description

2.1.1 Serial Interface

The TCP2RS has a serial port that supports RS-232 and RS-485 serial standards (firmware selectable) up to 115.2 Kbps.

Figure 2-1: Serial Interface

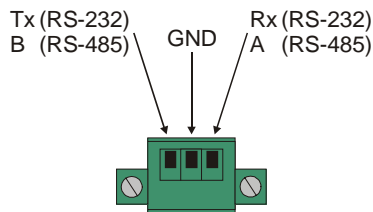

2.1.2 Network Interface

The TCP2RS's contains a reset switch, and an RJ45 (10Base-T) Ethernet port that supports up to 10 Mbps.

Figure 2-2: Network Interface

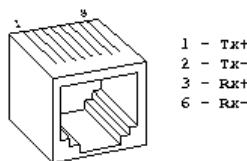

2.1.3 LEDs

Six LEDs are located on the top of the unit. The following table explains their functions:

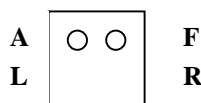

**Table 2-1: TCP2RS LEDs**

LED	Function
A (Yellow) Channel 2	If solid, channel 2 is idle. If blinking (1 sec cycle), the channel is connected over the network.
F (Red) Error and Diagnostic	This LED and LED 2 (Green) together indicate a series of diagnostic patterns.
L (Green) Network Link	Active if good link.
R (Green) Channel 1	It displays the status of channel 1. If solid, channel 1 is idle. If blinking (1 sec cycle), the channel is connected over the network. This LED is also used for diagnostic and error detection when combined with LED 1 (Red)
RX,TX	Serial communications.

2.1.4 Product Information Label

A product information label is located on the underside of the TCP2RS, and contains the following information about your specific unit:

- ◆ Serial Number
- ◆ Product ID (name)
- ◆ Product Description
- ◆ Ethernet Address (also referred to as Hardware Address or MAC Address)

2.2 Installing the TCP2RS

The following diagram shows a properly installed TCP2RS.

To install the TCP2RS, complete the following steps in order. Refer to the numbers in the previous figure.

- 1 Connect a serial device to the TCP2RS.
- 2 Connect an Ethernet cable to the 10BASE-T port.

- 3 Supply power to the TCP2RS.

Note: *The required input voltage is 220VAC.*

- 4 Supply power to the serial device.

3: Getting Started

This chapter covers the required steps to get the TCP2RS on-line and working. There are two basic methods used to log into the TCP2RS and setup the IP address:

- ◆ Network Port Login: Make a Telnet connection to the network port (port 9999).
- ◆ Serial Port Login: Connect a terminal or a PC running a terminal emulation program directly to the TCP2RS's serial port.

It is important to consider the following points before logging into and configuring the TCP2RS:

- ◆ The TCP2RS's IP address must be configured before a network connection is available.
- ◆ Only one person at a time may be logged into the configuration port (port 9999). This eliminates the possibility of several people simultaneously attempting to configure the TCP2RS.
- ◆ Network port logins cannot be disabled. The system manager will always be able to access the unit. However, this port can be password protected.
- ◆ Only one terminal at a time can be connected to the serial port. (In RS-485 mode, the TCP2RS is capable of multidrop connections.)

3.1 Default IP Address

The TCP2RS ships with a default IP address of 192.168.0.25, if you want to use DHCP you have to config IP 0.0.0.0 which automatically enables DHCP within the TCP2RS.

Provided a DHCP server exists on the network, it will supply the TCP2RS with an IP address, gateway address, and subnet mask when the TCP2RS boots up. (If no DHCP server exists, the TCP2RS will respond with a diagnostic error: the red Diagnostic LED

blinks continuously and the green Status LED blinks five times). This address will **not** appear in the TCP2RS's configuration screens; however, if you enter Monitor Mode from the serial port with network connection enabled (see Monitor Mode), and issue the **NC** command, you will see the TCP2RS's IP configuration.

3.2 IP Address Configuration

The TCP2RS's IP address must be configured before a network connection is available. If the IP address was not set automatically via DHCP, set it now using a network or serial port login and the setup (configuration) menu.

3.2.1 Network Port Login (1)

The easiest way for setting up the IP direction of the TCP2RS converter is using the little utility called TCP2RSSetup that comes with the converter.

First of all we will write down Ethernet address that comes printed on every device label. This address is unique and different from other network devices. It's the hardware address that every interface has (something like 00-20-4A-61-05-19).

Into the "Extras" disc that comes with the converter, there is an Utility called TCP2RSSetup. This utility is made for configuring the IP address of the converter. Steps:

- 1- Start the program
- 2- Insert the Hardware address that comes with the converter, and desired IP address.
- 3- Click *Configurar* (This will assign temporarily an IP address to the converter and opens an internet explorer page for configuring it)
- 4- Click *Connect* and *Server Properties*
- 5- Enter desired IP and netmask and click *Update settings*

Note: *This utility only links IP address with hardware address, but it is not stored in device's memory, until we enters into config mode and update this settings.*

3.2.2 Network Port Login (2)

The ARP method is available under UNIX and Windows-based systems. If the TCP2RS has no IP address, it will set its address from the first directed TCP/IP packet it receives.

- 1 On a **UNIX** host, create an entry in the host's ARP table using the intended IP

address and the hardware address of the TCP2RS, which is found on the product label.

Figure 3-1: ARP on UNIX

```
arp -s 191.12.3.77 00:20:4a:xx:xx:xx
```

In order for the ARP command to work on **Windows**, the ARP table on the PC must have at least one IP address defined other than its own. If the ARP table is empty, the command will return an error message. Type ARP -A at the DOS command prompt to verify that there is at least one entry in the ARP table.

If the local machine is the only entry, ping another IP address on your network to build a new entry in the ARP table; the IP address must be a host other than the machine on which you are working. Once there is at least one additional entry in the ARP table, use the following command to ARP an IP address to the TCP2RS:

Figure 3-2: ARP on Windows

```
arp -s 191.12.3.77 00-20-4a-xx-xx-xx
```

- 2 Now open a Telnet connection to port 1. The connection will fail quickly, but the TCP2RS will temporarily change its IP address to the one designated in this step.

Figure 3-3:

```
telnet 191.12.3.77 1
Telnet to Port 1
```

- 3 Finally, open a Telnet connection to port 9999 and set all required parameters.

Figure 3-4: Telnet to Port 9999

```
telnet 191.12.3.77 9999
```

Note: *This IP address is temporary and will revert to the default value when the TCP2RS's power is reset, unless you log into the TCP2RS and store the changes permanently. Refer to Chapter 4 for instructions on permanently configuring the IP address.*

3.2.3 Serial Port Login

- 1 Connect a console terminal or PC running a terminal emulation program to the TCP2RS's serial port. The default serial port settings are 9600 baud, 8 bits, no parity, 1 stop bit.

- 2 To enter Setup (configuration) Mode, cycle the TCP2RS's power (power off and back on). After power-up the self-test begins and the red Diagnostic LED starts blinking. You have one second to enter three lowercase "x" characters.

Note: *The easiest way to enter Setup Mode is to hold down the "x" key at the terminal (or emulation) while powering up the TCP2RS.*

- 3 Select **0** (Server Configuration) and follow the prompts until you get to IP address.
- 4 Enter the new IP address.
- 5 Select **9** to save the configuration and exit Setup Mode.

The TCP2RS performs a power reset.

4: Configuration

Certain parameters must be configured before the TCP2RS can function on a network. The TCP2RS can be locally or remotely configured using the following procedures:

- ◆ Use a standard Web browser to access the TCP2RS's internal Web pages and configure the unit over the network. This is the easiest and preferred method.
- ◆ Use a Telnet connection to configure the unit over the network.
- ◆ Use a terminal or terminal emulation program to access the serial port locally.

The TCP2RS's configuration is stored in nonvolatile memory (NVRam) and is retained without power. The configuration can be changed at any time. The TCP2RS performs a reset after the configuration has been changed and stored.

4.1 Network Configuration

4.1.1 Using a Web Browser

If your TCP2RS already has an IP address (see Chapter 3, *Getting Started*), you can log into it using a standard Web browser with Java enabled.

- 1 Type the TCP2RS's IP address into the Web browser's URL (Address/Location) field.

Once you have connected to the TCP2RS, you will see the device Web Manager interface.

- 2 Select **Connect** to login and gain access to the configuration menu.
- 3 Use the menu to navigate to subpages where you can configure server settings.

Figure 4-1: Web Manager Interface

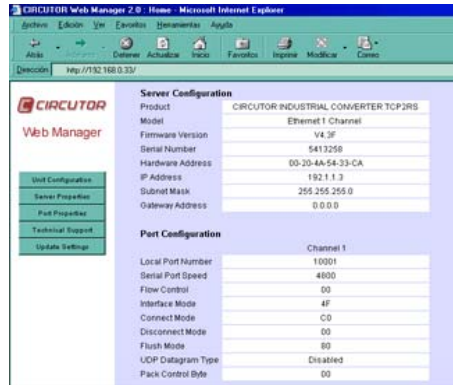

4.1.2 Using a Telnet Connection

To configure the TCP2RS over the network, establish a Telnet connection to port **9999**. For Windows, open an MS-DOS command window and enter the following command, where x.x.x.x is the IP address and 9999 is the TCP2RS's fixed network console port number.

Figure 4-2:

```
Telnet x.x.x.x 9999
Network Login Using Telnet
```

Note: *Be sure to include a space between the IP address and 9999.*

4.2 Serial Configuration

For local configuration, a terminal or a PC running a terminal emulation program can be connected to the TCP2RS's serial port. The terminal (or emulation) should be configured for 9600 baud, 8-bit, no parity, 1 stop bit and without flow control.

To enter Setup (configuration) Mode, cycle the TCP2RS's power (power off and back on). After power-up, the self-test begins and the Diagnostic and Status LEDs start blinking. You must enter three lowercase "x" characters (**xxx**) within one second after powering up in order to start the configuration mode.

Note: *The easiest way to enter Setup Mode is to hold down the "x" key on your keyboard while powering up the TCP2RS.*

4.3 Configuration Parameters

After entering Setup Mode (confirm by typing **Enter**), you can configure the parameters by entering one of the numbers on the Change Setup Menu, or you can confirm default

values by typing **Enter**. Be sure to store the new configurations when you are finished. The TCP2RS will then perform a power reset.

Figure 4-3: Setup (Configuration) Mode Screen

```

*** Circutor ***
Serial Number 1400280  MAC address 00:20:4A:14:01:18
Software Version 04.5 (000428)
Press Enter to go into Setup Mode

*** basic parameters
Hardware: Ethernet Autodetect
IP addr 192.168.011.141, no gateway set

***** Channel 1 *****
Baudrate 09600, I/F Mode 4C, Flow 00
Port 10001
Remote IP Adr: --- none ---, Port 00000
Connect Mode: C0      Disconn Mode: 00
Flush Mode: 00

Change Setup: 0 Server configuration
               1 Channel 1 configuration
               7 Factory defaults
               8 Exit without save
               9 Save and exit      Your choice ?
    
```

Setup Options:

0 Server Configuration	IP Address: (192).(168).(000).(030) Set Gateway IP Address (N) N Netmask: Number of Bits for Host Part (0=default) (08) Change telnet config password (N) N
1 Channel 1 Configuration	Baudrate (9600) I/F Mode (4C) ? Flow (00) ? Port No (10001) ? ConnectMode (C0) ? Remote IP Address : (000).(000).(000).(000) Remote Port (00000) ? DisConnMode (00) ? FlushMode (00) ? DisConnTime (00 :00) ? SendChar 1 (00) ? SendChar 2 (00) ?
7 Factory defaults	Disable Telnet Setup (N) N Disable TFTP firmware update (N) N

	Disable Port 77Feh (N) N Disable web setup (N) N Enable enhanced password (N) N
8 Exit without save	
9 Save and exit	

4.4 Server Configuration

Select **0** to configure the TCP2RS's basic parameters.

4.4.1 IP Address

The IP address must be set to a unique value in your network. See Appendix F for more information about IP Addressing.

Note: *The TCP2RS cannot connect to the network if the assigned IP address is already in use by another device.*

4.4.2 Gateway Address

The gateway address, or router, allows communication to other LAN segments. The gateway address should be the IP address of the router connected to the same LAN segment as the TCP2RS.

Note: *The gateway address must be within the local network.*

4.4.3 Netmask

A netmask defines the number of bits taken from the IP address that are assigned for the host section.

Note: *Class A: 24 bits; Class B: 16 bits; Class C: 8 bits.*

The TCP2RS prompts for the number of host bits to be entered, then calculates the netmask, which is displayed in standard decimal-dot notation when the saved parameters are displayed (for example, 255.255.255.0).

4.4.4 Telnet Configuration Password

Setting the Telnet configuration password prevents unauthorized access of the setup menu via a Telnet connection to port 9999. The password is limited to 4 characters.

Note: *No password is required to access the setup menu via a serial connection.*

4.5 Serial Channel (Port) Configuration

Select **1** to configure the TCP2RS's channel-specific parameters.

4.5.1 Baud Rate

The TCP2RS and attached serial device, such as a modem, must agree on a speed or baud rate to use for the serial connection. Valid baud rates are 300, 600, 1200, 2400, 4800, 9600 (default), 19200, 38400, 57600, and 115200 bits per second.

4.5.2 Interface Mode

The Interface (I/F) Mode is a bit-coded byte entered in hexadecimal notation.

Table 4-1: Interface Mode Options

Option	Bit 7	6	5	4	3	2	1	0
RS-232C							0	0
RS-485							0	1
RS-485 2-wire							1	1
7 Bit					1	0		
8 Bit					1	1		
No Parity			0	0				
Even Parity			1	1				
Odd Parity			0	1				
1 Stop bit	0	1						
2 Stop bits	1	1						

The following table demonstrates how to build some common Interface Mode settings:

Table 4-2: Common Interface Mode Settings

Option	Binary	Hex
RS-232C, 8-bit, No Parity, 1 stop bit	0100 1100	4C
RS-232C, 7-bit, Even Parity, 1 stop bit	0111 1000	78
RS-485 2-Wire, 8-bit, No Parity, 1 stop bit	0100 1111	4F

Note: See Appendix B for more information on converting binary values to hexadecimal format.

4.5.3 Flow Control

Flow control sets the local handshake method for stopping serial input/output. Generally, flow control is not required if the connection is used to pass a blocked protocol with block sizes less than 1k (ACK/NAK).

Table 4-3: Flow Control Options

Option	Hex
No flow control	00
XON/XOFF flow control	01
Hardware handshake with RTS/CTS lines	02
XON/XOFF pass characters to host	05

4.5.4 Port Number

The setting represents the source port number in TCP connections, and is the number used to identify the channel for remote initiating connections. Range: 1-65535.

Note: Port numbers 0, 7, and 9999 are reserved. Port numbers 14000-14009 are reserved for use with the Comm Port Redirector application (see Comm Port Redirector on page 5-1).

If the UDP mode is selected, the port number functions as the UDP source port number for outgoing datagrams. Datagrams sent to the TCP2RS with this port number are received to this channel.

4.5.5 Connect Mode

Connect Mode defines how the TCP2RS makes a connection, and how it reacts to incoming connections over the network.

Table 4-4: Connect Mode Options

Option	Bit 7	6	5	4	3	2	1	0
Incoming Connection								
Never accept incoming	0	0	0					
Accept incoming with DTR	0	1	0					
Accept unconditional	1	1	0					

Response							
Nothing (quiet)			0				
Character response (C=conn, D=disconn, N=unreachable)			1				
Startup							
No active startup			0	0	0	0	
With any character			0	0	0	1	
With active DTR			0	0	1	0	
With CR (0x0D) only			0	0	1	1	
Manual connection			0	1	0	0	
Autostart			0	1	0	1	
Datagram Type							
Directed UDP			1	1	0	0	
Modem Mode							
With Echo			1	0	1	1	0
Without Echo			0	0	1	1	0

Note: See Appendix B for information on converting binary values to hexadecimal format.

4.5.5.1 Manual Connection

If manual connection startup is configured (C + address/port), only the portion not provided in the command string is used. In manual mode, the last byte of the address must be provided.

For example, if the TCP2RS's configured remote IP address is 129.1.2.3 and the TCP port number is 1234:

Table 4-5: Manual Connection Address Example

Command String	Result
C121.2.4.5/1	Complete override; connection is started with host 121.2.4.5, port 1
C5	Connect to 129.1.2.5, port 1234
C28.10/12	Connect to 129.1.28.10, port 12

4.5.5.2 Autostart (Automatic Connection)

For the serial port, automatic TCP connection to a network node can be configured by setting the remote IP address and the TCP port number parameters. If automatic connection is selected, all parameters must be provided.

4.5.5.3 Datagram Type

When selecting this option, you will be prompted for the Datagram type. Enter **01** for directed UDP.

4.5.5.4 Modem (Emulation) Mode

In Modem Mode, the TCP2RS presents a modem interface to the attached serial device. It accepts AT-style modem commands, and handles the modem signals correctly.

Normally there is a modem connected to a local PC and a modem connected to a remote machine. A user must dial from the local PC to the remote machine, accumulating phone charges for each connection. Modem Mode allows you to replace modems with TCP2RS, and to use an Ethernet connection instead of a phone call, without having to change communications applications and make potentially expensive phone calls.

Note: *If the TCP2RS is in Modem Mode and the serial port is idle, the TCP2RS can still accept network TCP connections to the serial port if Connect Mode is set to **C6** (no echo) or **D6** (echo).*

Modem Mode is selected by setting the connect mode to **06** (no echo) or **16** (echo).

Table 4-6: Modem Mode Commands

Command	Function
ATDTx.x.x.x,pppp or ATDTx.x.x.x/pppp	Makes a connection to an IP address (x.x.x.x) and a remote port number (pppp).
ATDTx.x.x.x	Makes a connection to an IP address (x.x.x.x) and the remote port number defined within the TCP2RS.
ATD0.0.0.0	Forces the TCP2RS into monitor mode if a remote IP address and port number are defined within the TCP2RS.
ATD	Forces the TCP2RS into monitor mode if a remote IP address and port number are not defined within the TCP2RS.
ATDx.x.x.x	Makes a connection to an IP address (x.x.x.x) and the remote port number defined within the TCP2RS.
ATH	Hangs up the connection (Entered as +++ATH).

Note: *All other AT commands with Modem Mode set to **16** acknowledge with an OK, but no action is taken.*

4.5.6 Remote IP Address

Selecting Autostart (automatic connection) in Connect Mode makes a connection to this IP address on the network. This is the destination IP address used with an outgoing

connection.

4.5.7 Remote Port

The remote TCP port number must be set to use automatic connections. This parameter defines the port number on the target host to which a connection is attempted.

Note: *To connect an ASCII terminal to a host using the TCP2RS for login purposes, use the remote port number 23 (Internet standard port number for Telnet services).*

4.5.8 Disconnect Mode

In Disconnect Mode, DTR drop either drops the connection or is ignored.

Table 4-7: Disconnect Mode Options

Option	Bit 7	6	5	4	3	2	1	0
Disconnect with DTR drop	1							
Ignore DTR	0							
Telnet mode and terminal type setup		1						
Channel (port) password				1				

Note: *See Appendix B for information on converting binary values to hexadecimal format.*

4.5.9 Flush Mode (Buffer Flushing)

Using this parameter, you can control line handling and network buffers with connection startup and disconnect. You can also select between two different packing algorithms.

Table 4-8: Flush Mode Options

Function	Bit 7	6	5	4	3	2	1	0
Input Buffer (Serial to Network)								
Clear active connection (from serial)				1				
Clear passive connection (from network)			1					
Clear at disconnect		1						
Output Buffer (Network to Serial)								
Clear active connection (from network)								1
Clear passive connection (from serial)							1	
Clear at disconnect						1		
Alternate Packing Algorithm								

Enable	1								
--------	---	--	--	--	--	--	--	--	--

Note: See Appendix B for information on converting binary values to hexadecimal format.

4.5.10 Pack Control

Alternate packing algorithm settings are enabled in Flush Mode. Set this value to 00 if specific functions are not needed.

Table 4-9: Pack Control Options

Option	Bit 7	6	5	4	3	2	1	0
Idle Time								
Force transmit: 12ms							0	0
Force transmit: 52ms							0	1
Force transmit: 250ms							1	0
Force transmit: 5sec							1	1
Trailing Characters								
None					0	0		
One					0	1		
Two					1	0		
Send Characters								
Enable				1				
Send Immediately After Sendchars			1					

Note: See Appendix B for information on converting binary values to hexadecimal format.

4.5.10.1 Idle Time

Idle time to "Force transmit" defines how long the TCP2RS should wait before sending accumulated characters, regardless of the recognition of send characters.

4.5.10.2 Trailing Characters

In some applications, CRC, Checksum, or other trailing characters follow the end-of-sequence character; this option helps to adapt frame transmission to the frame boundary.

4.5.10.3 Send Characters

If send characters are enabled, the TCP2RS interprets the sendchars as a 2-byte sequence; if not set, they are interpreted independently.

If "Send Immediately After Characters" is **not** set, any characters already in the serial buffer are included in the transmission after a "transmit" condition is found. If set, the TCP2RS sends immediately after recognizing the transmit condition (sendchar or timeout).

Note: *A transmission might occur if status information needs to be exchanged or an acknowledgment needs to be sent.*

4.5.11 Inactivity (Disconnect) Timeout

Use this parameter to set an inactivity timeout. The connection is dropped if there is no activity on the serial line before the set time expires. Enter time in the following format: mm:ss, where "m" is the number of minutes and "s" is the number of seconds. To disable the inactivity timeout, enter **00:00**.

4.5.12 Send Characters

You can enter up to two characters in hexadecimal representation in the parameters "sendchar". If a character received on the serial line matches one of these characters, it is sent immediately, along with any awaiting characters, to the TCP connection. This minimizes the response time for specific protocol characters on the serial line (for example, ETX, EOT, etc.). Setting the first sendchar to **00** disables the recognition of the characters.

Alternatively, the two characters can be interpreted as a sequence (see Pack Control on page 4-11).

4.5.13 Telnet Terminal Type

This parameter appears only if the terminal type option is enabled in Disconnect Mode (see Disconnect Mode). If set, you can use the terminal name for the Telnet terminal type. Enter only one name.

If the terminal type option is enabled, TCP2RS also reacts to the EOR (end of record) and binary options, which can be used for applications like terminal emulation to IBM hosts.

4.5.14 Channel (Port) Password

This parameter appears only if the channel (port) password option is enabled in Disconnect Mode (see Disconnect Mode). If set, you can set a password on the serial port.

4.6 Factory Default Settings

Select **7** to reset the TCP2RS's serial port to the factory default settings. The server configurations remain unchanged.

4.7 Exit Configuration Mode

Select **8** to exit the configuration mode without saving any changes, or select **9** to exit and save all changes. All values are stored in nonvolatile memory, and the TCP2RS resets.

5: Using the TCP2RS

5.1 Comm Port Redirector

The Comm Port Redirector application allows PCs to share modems and other serial devices connected to a TCP2RS using Windows-based applications. The Comm Port Redirector intercepts communications to specified COM ports and sends them over an IP network connection to the TCP2RS's serial port. This enables the PC to use the TCP2RS's serial port as if it were one of the PC's COM ports. Using their existing communications software, users can dial out to a remote host through a modem connected to the TCP2RS.

5.1.1 Redirector Setup

To setup the Comm Port Redirector software:

- 1 Install the Redirector software. The software and installation instructions are included on the distribution discs.
- 2 In the Redirector's configuration screen, select **Port Setup** and add as many COM ports as you need (for example, one for each TCP2RS).
- 3 Under each port, select **Add IP** and enter the IP address (**Host**) of the TCP2RS that you want to assign to that port, and a number between 3000 and 3009 (**TCPPort**).

Note: *Remember the TCPPort number. You will need it to configure the TCP2RS.*

- 4 Save the configurations and reboot your PC.

5.1.2 TCP2RS Configuration

The following procedure should be repeated for each TCP2RS defined in the Redirector setup, above.

- 1 Enter the TCP2RS's Setup (configuration) Mode (see Chapter 4).
- 2 Set the **Port Number** to a value that is 11000 higher than the TCPPort number selected in the Redirector setup, above (for example, if the TCPPort number was 3005, set the TCP2RS's Port Number to 14005).
- 3 Save the configurations and exit Setup Mode.

Note: *When using the Redirector, the TCP2RS does not change its serial port configuration to match the PC application's serial settings. Ensure that the TCP2RS serial port's configuration matches the configuration of your serial device.*

5.2 Monitor Mode

Monitor Mode is a command-line interface used for diagnostic purposes (see Table 5-1: Monitor Mode Commands). There are two ways to enter Monitor Mode: locally via the serial port or remotely via the network.

5.2.1 Via the Serial Port

To enter Monitor Mode locally:

- 1 Follow the same principals used in setting the serial configuration parameters (see Serial Configuration).

Instead of typing three "x" keys, however, type **xx1** to enter Monitor Mode with network connections.

Type **xx2** or **yyy** to enter Monitor Mode **without** network connections.

- 2 A **0>** prompt indicates that you have successfully entered Monitor Mode.

5.2.2 Via the Network

To enter Monitor Mode using a Telnet connection:

- 1 First establish a Telnet session. The following message appears:

Figure 5-1: Entering Monitor Mode Via the Network

```
*** Circutor ***
Serial Number 1400280  MAC address 00:20:4A:14:01:18
Software Version 04.0b7 (000428)
Press Enter to go into Setup Mode
```

- 2 Type **M** (upper case).
- 3 A **0>** prompt indicates that you have successfully entered Monitor Mode.

5.2.3 Monitor Mode Commands

The following commands are available in Monitor Mode. Many commands have an IP address as an optional parameter (x.x.x.x). If the IP address is given, the command is applied to another Device Server with that IP address. If no IP address is given, the command is executed locally.

Note: *All commands must be given in capital letters, with blank spaces between the parameters.*

Table 5-1: Monitor Mode Commands

Command	Command Name	Function
DL	Download	Download firmware to the TCP2RS
SF x.x.x.x	Send Firmware	Send firmware to Device Server with IP address x.x.x.x
VS x.x.x.x	Version	Query software header record (16-byte) of Device Server with IP address x.x.x.x
GC x.x.x.x	Get Configuration	Get configuration of Device Server with IP address x.x.x.x as hex records
SC x.x.x.x	Send Configuration	Set configuration of Device Server with IP address x.x.x.x from hex records
PI x.x.x.x	Ping	Ping Device Server with IP address x.x.x.x to check device status
AT	ARP Table	Show the TCP2RS's ARP table entries
TT	TCP Connection Table	Shows all incoming and outgoing TCP connections (used only with monitor mode)
NC	Network Connection	Shows the TCP2RS's IP configuration
RS	Reset	Resets the TCP2RS's power
SI x.x.x.x:n.n.n.n	Send/Set IP Address	Remotely assign an IP address to a Device Server, where x.x.x.x is the new IP address and n.n.n.n is the remote Device Server's serial number written twice
QU	Quit	Exit diagnostics mode

Entering any of the commands listed above will generate one of the following command response codes:

Table E-2: Command Response Codes

Response	Meaning
0>	OK; no error
1>	No answer from remote device
2>	Cannot reach remote device or no answer

8>	Wrong parameter(s)
9>	Invalid command

A: Contact Information

If you are experiencing an error that is not listed in Appendix B, or if you are unable to fix the error, there are a number of other troubleshooting options:

- ◆ Look on the discs that were included in your package for additional documentation and support information
- ◆ Look on the Circutor Web site for technical FAQs and documentation updates.
- ◆ For information pertaining to your system's configuration, refer to your system's documentation or technical support. For example, for specific questions about the Microsoft Windows Operating System, refer to the Microsoft Knowledge Base Web site at www.support.microsoft.com/directory.
- ◆ Contact your dealer or Circutor Technical Support at +34 937452900. Technical Support is also available via Internet email at **central@circutor.com**.

A.1 Problem Report Procedure

When you report a problem, please provide the following information:

- ◆ Your name
- ◆ Your company name, address, and phone number
- ◆ Product model number
- ◆ Serial number
- ◆ Software version
- ◆ Network configuration
- ◆ Description of the problem
- ◆ Debug report (stack dump), if applicable
- ◆ Status of the unit when the problem occurred (please try to include information on user and network activity at the time of the problem)

A.2 Full Contact Information

Address: Lepanto, 49 08223 TERRASSA (Barcelona) - SPAIN

Phone: +34 93 745 29 00

Fax: +34 93 745 29 14

e-mail: central@circutor.es World Wide Web: <http://www.circutor.com>

B: Binary to Hexadecimal Conversion

Many of the TCP2RS's configuration procedures require you to assemble a series of options (represented as bits) into a complete command (represented as a byte). The resulting binary value must be converted to a hexadecimal representation.

Hexadecimal digits have values ranging from 0 to F, which are represented as 0-9, A (for 10), B (for 11), etc. To convert a binary value (for example, 0010 0011) to a hexadecimal representation, the upper and lower four bits are treated separately, resulting in a two-digit hexadecimal number (in this case, 4C).

Use the following table to convert values from binary to hexadecimal.

Table B-1: Binary to Hexadecimal Conversion Table

Decimal	Binary	Hex
0	0000	0
1	0001	1
2	0010	2
3	0011	3
4	0100	4
5	0101	5
6	0110	6
7	0111	7
8	1000	8
9	1001	9
10	1010	A
11	1011	B
12	1100	C
13	1101	D
14	1110	E
15	1111	F

C: Pinouts

Figure 1: General Diagram

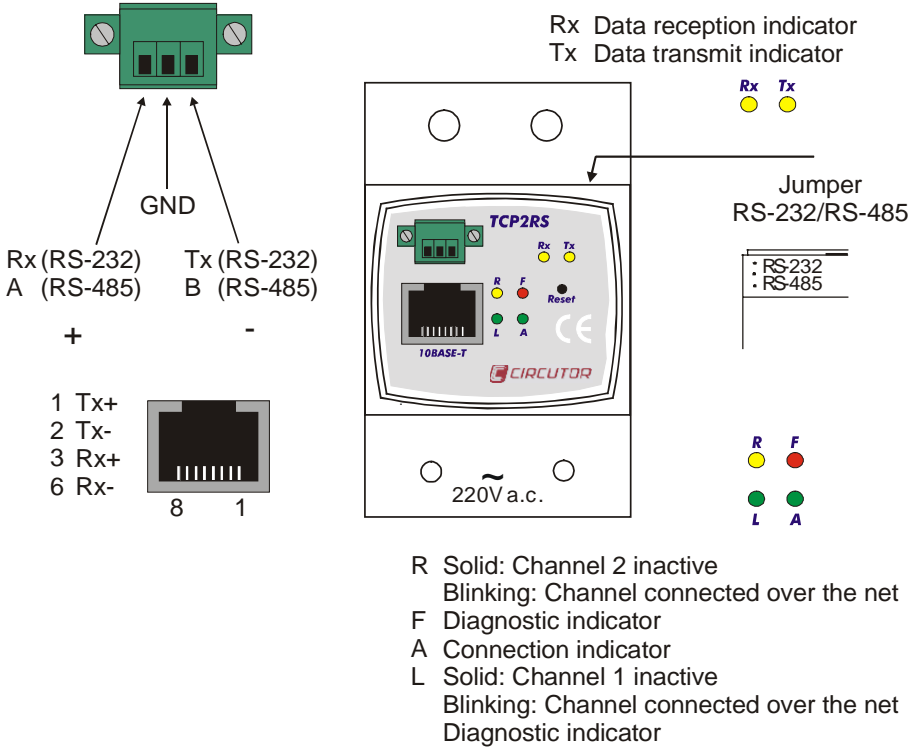

C.1 Ethernet Connector

Figure 2: Network Interface

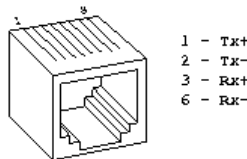

C.2 Serial Connector

Figure 3: Serial Interface

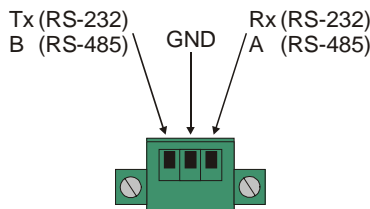

C.3 Serial and Ethernet Wires

Standard Serial Wire

Connections diagram of an standard serial wire for connecting any RS-232 serial device to the TCP2RS.

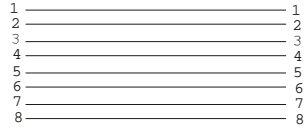

Figure 4: Serial wire with male connector

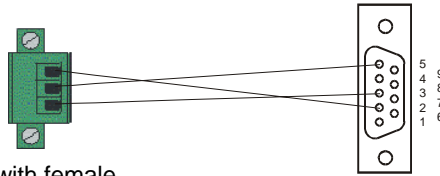
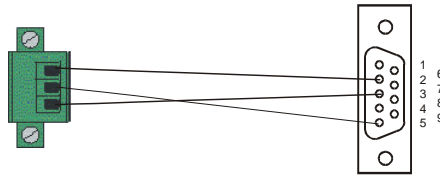

Figure 5: Serial wire with female

connector



Standard Ethernet Wire

Connections diagram, of a Cat.5 Ethernet wire, for connecting any Ethernet device (like TCP2RS) to a HUB.

(We will connect each wire ends with the same colours configuration, trying to take pins 1 and 2 (ex. Orange - Orange/White) and pins 3 and 6 (ex. Green – Green/White) like a twisted pair)

Example:

- | | |
|-----------------|----------------|
| 1- Orange | 5- Blue/White |
| 2- Orange/White | 6- Green/White |
| 3- Green | 7- Brown |
| 4- Blue | 8- Brown/White |

Direct Ethernet Wire

Connections Diagram of a Cat.5 Ethernet wire for connecting any Ethernet device (like TCP2RS) directly to another like a PC.

(What we have to do is to take the transmission wires of one end, and link it with the reception pins of the other end. Pins 1 and 2 are for transmission, and pins 3 and 6 for reception. We will connect 1 and 2 of one end (ex. Orange – Orange/White) with 3 and 6 of the other end, and 3 and 6 of the first end (ex. Green – Green/White) with pins 1 and 2 of the other end). We ha to try to take a twisted pair for transmission and another for reception.

Example:

WIRE END 1

WIRE END 2

1- Orange

1- Green

2- Orange/White

2- Green/White

3- Green

3- Orange

4- Blue

4- Blue

5- Blue/White

5- Blue/White

6- Green/White

6- Orange/White

7- Brown

7- Brown

8- Brown White

8- Brown/White

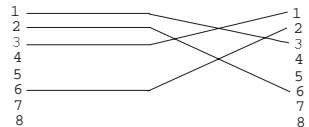

D: Updating Firmware

D.1 Obtaining Firmware

Current firmware files are available on the distribution CD. Firmware updates and release notes for the TCP2RS can be downloaded directly from Circutor via the Circutor World Wide Web site (www.circutor.com/tcp2rs.htm).

D.2 Reloading Firmware

There are three ways to update the TCP2RS's internal operational code (LTX*.ROM or LTX*.HEX): via TFTP, via another device server, or via the serial port.

You can also update the TCP2RS's internal Web interface (LTXW*.COB) via TFTP.

D.2.1 Via TFTP

To download new firmware from a computer:

- 1 Use a TFTP client to send a binary file to the TCP2RS (LTX*.ROM to upgrade the TCP2RS's internal operational code and LTXW*.COB to upgrade its internal Web interface).

Note: *TFTP requires the .ROM (binary) version of the TCP2RS's internal operational code.*

- A** Include the full path in the **Source File**.
- B** The **Destination File** is **3Q** (upper case) for the internal operational code and **WEB1** for the internal Web interface.
- C** **Remote Host** is the IP address of the unit being upgraded.
- D** Select **Put** to transfer the file to the TCP2RS.

Figure D-1: TFTP Dialog Box

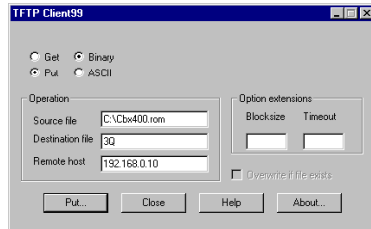

- 2 If you don't have a graphical tftp program, you can upload the firmware using tftp.exe program that comes with any windows 2000 or NT.

```
tftp -i 192.168.0.25 put circutor.cob WEB1
```

```
tftp -i 192.168.0.25 put ltx455.rom 3Q
```

- 3 The TCP2RS performs a power reset after the configuration has been changed and stored.

D.2.2 Via Another Device Server

To distribute firmware to another Device Server over the network:

- 1 Enter the host TCP2RS's Monitor Mode (see Monitor Mode).
- 2 Send the firmware to the receiving Device Server using the **SF** command, where x.x.x.x is the receiving Device Server's IP address.

Figure D-2: Sending Firmware to Another Device Server

```
SF x.x.x.x
```

- 3 The TCP2RS performs a power reset after the configuration has been changed and stored.

Note: *You can only update the TCP2RS's internal Web interface using TFTP.*

D.2.3 Via the Serial Port

To download firmware from a computer via the TCP2RS's serial port:

- 1 Enter Monitor Mode (see Monitor Mode on page 5-2).
 - 2 Download the firmware to the TCP2RS using the **DL** command.
 - A** Select **Send Text File** and select the LTX*.HEX file to be downloaded.
- Note:** *The downloaded file must be the .HEX (ASCII) version.*
- 3 After the final record is received, the TCP2RS checks the integrity of the firmware image before programming the new firmware in the flash ROM.

Note: *Do not switch off the power supply at this time. A loss of power while reprogramming will result in a corrupt program image and a nonfunctional TCP2RS. This process may take up to 10 minutes.*
 - 4 The following message displays when the firmware upgrade is complete.

Figure D-3: Firmware Upgrade Screen Display

```
*** NodeSet 2.0 ***  
0>DL  
02049 lines loaded.  
Max Address FFE0  
Loading EEPROM ...
```

- 5 The TCP2RS performs a power reset after the configuration has been changed and stored.

Note: *You can only update the TCP2RS's internal Web interface using TFTP.*

E: Technical Specifications

E.1 CPU, Memory Controllers

- ◆ AMD 188ES CPU, 25MHz
- ◆ Realtek Ethernet Controller
- ◆ 128kByte RAM, 512kByte Flash PROM

E.2 Serial Interface

- ◆ Speed software selectable (300 to 115 kBaud)
- ◆ Software selectable RS-232C or RS-485

E.3 Network Interface

- ◆ 10Base-T (RJ45 connector)

E.4 Power Supply

- ◆ Internal
- ◆ 230VAC

E.5 Dimensions

- ◆ Height: 5.2 cm
- ◆ Width: 7.0 cm
- ◆ Depth: 4.5 cm

E.6 Environmental Limitations

E.6.1 Temperature

- ◆ Operating range: 5° to 50° C (41° to 122° F)

- ◆ Storage range: -40° to 66° C (-40° to 151° F)
- ◆ Maximum temperature change per hour: 20° C (36° F)

Note: *Maximum temperature changes may affect operation. Therefore, do not operate the TCP2RS near heating or cooling devices, large windows, or doors that open to the outdoors.*

E.6.2 Altitude

- ◆ Operating: 2.4 km (8,000 ft) maximum
- ◆ Storage: 9.1 (30,000 ft) maximum

Note: *If operating the TCP2RS above 2.4 km (8,000 ft), decrease the operating temperature rating by 1° for each 1000 ft.*

E.6.3 Relative Humidity

- ◆ Operating: 10% to 90% noncondensing, 40% to 60% recommended
- ◆ Storage: 10% to 90% noncondensing

F: IP Addressing

Every device connected to a TCP/IP network must have a unique IP (Internet Protocol) address. This address is used to reference the specific device; for example, to build a connection to the TCP2RS's serial port.

An IP address is a 32-bit value divided into four octets of eight bits each. The standard representation is four decimal numbers (0-255) divided by dots (decimal dot notation).

Figure F-1: Sample IP Address

192.2.12.123 (or 192.002.012.123)

The IP address is divided into two parts: network and host. To support different needs, three network classes have been defined. In the following, "x" stands for the host part of the IP address.

F.1 Class A Network

IP address 1.x.x.x to 127.x.x.x

The first byte defines the host, and the last three bytes define the network. Only 127 different Class A networks exist, and each can consist of up to 16,777,216 devices.

Figure F-2: Sample Class A Network IP Address

10.0.0.1 (network 10, host 0.0.1)

F.2 Class B Network

IP address 128.0.x.x to 191.255.x.x

The first two bytes define the host, and the last two bytes define the network. Class B networks are typically used for large company networks, and each can consist of up to 65,534 devices.

Figure F-3: Sample Class B Network IP Address

172.1.3.2 (network 172.1, host 3.2)

F.3 Class C Network

IP address 192.0.0.x to 223.255.255.x

The first three bytes define the host, and the last byte defines the network. Class C networks are the most common and are often used in smaller companies. Each network can consist of up to 254 hosts.

Figure F-4: Sample Class C Network IP Address

192.7.1.9 (network 192.7.1, host 9)

F.4 Class D Network

IP address 224.x.x.x to 239.x.x.x

These addresses are used as multicast addresses.

F.5 Class E Network

IP address 239.x.x.x to 254.x.x.x

These addresses are reserved.

F.6 Network Address

A host address with all host bits set to **0** addresses the network as a whole (for example, in routing entries).

Figure F-5: Sample Network Address

192.168.0.0

F.7 Broadcast Address

A host address with all host bits set to **1** is the broadcast address, meaning for “for every station.”

Figure F-6: Sample Broadcast Address

192.168.0.255

Network and broadcast addresses must not be used as a host address; for example, 192.168.0.0 identifies the entire network, and 192.168.0.255 identifies the broadcast

address.

F.8 IP Netmask

A netmask divides IP address differently than the standards defined by the classes A, B, and C. A netmask defines the number of bits to be taken from the IP address as the network or host sections. The TCP2RS prompts for the number of host bits to be entered and then calculates the netmask, which is displayed in standard decimal-dot notation (for example, 255.255.255.0) when saved parameters are displayed.

Table F-1: Standard IP Network Netmasks

Network Class	Network Bits	Host Bits	Netmask
A	8	24	255.0.0.0
B	16	16	255.255.0.0
C	24	8	255.255.255.0

Table F-2: Netmask Examples

Netmask	Host Bits
255.255.255.252	2
255.255.255.248	3
255.255.255.240	4
255.255.255.224	5
255.255.255.192	6
255.255.255.128	7
255.255.255.0	8
255.255.254.0	9
255.255.252.0	10
255.255.248.0	11
...	...
255.128.0.0	23
255.0.0.0	24

F.9 Private IP Networks and the Internet

If your network is not and will not be connected to the Internet, you may use any IP address. If your network is connected or will be connected to the Internet, or if you

intend to operate the TCP2RS on an intranet, you should use one of the reserved sub-networks. Consult your network administrator with questions about IP address assignment.

F.10 Network RFCs

For more information about IP addresses, refer to the following documents, which can be located on the World Wide Web using one of the following directories or indices:

- ◆ RFC 950 Internet Standard Subnetting Procedure
- ◆ RFC 1700 Assigned Numbers
- ◆ RFC 1117 Internet Numbers
- ◆ RFC 1597 Address Allocation for Private Networks